

Impro
Fluidtek

Technical Information

Orbital Motors Type WG



TABLE OF CONTENTS

TECHNICAL INFORMATION

Operating Recommendations 4-5
 Motor Connections 5
 Product Testing (Understanding the Performance Charts) 6
 Allowable Bearing & Shaft Loads 7
 Vehicle Drive Calculations 8-9
 Induced Side Loading 10
 Hydraulic Equations 10
 Shaft Nut Dimensions & Torque Specifications 11

OPTIONAL MOTOR FEATURES

Speed Sensor Options 12-13
 Freeturning Rotor Option 13
 Internal Drain 14
 Hydraulic Declutch 14
 Valve Cavity Option 15
 Slinger Seal Option 15

LIGHT DUTY HYDRAULIC MOTORS

WG Product Line Introduction 16
 WG Displacement Performance Charts 17-22
 275 & 276 Series Housings 23-24
 275 & 276 Series Technical Information 25
 275 & 276 Series Shafts 26
 275 & 276 Series Ordering Information 27
 277 & 278 Series Housings 28-29
 277 & 278 Series Technical Information 30
 277 & 278 Series Shafts 31
 277 & 278 Series Ordering Information 32
 280 & 281 Series Housings 33-34
 280 & 281 Series Shafts 34
 280 & 281 Series Technical Information 35
 280 & 281 Series Ordering Information 36

OPERATING RECOMMENDATIONS

OIL TYPE

Hydraulic oils with anti-wear, anti-foam and demulsifiers are recommended for systems incorporating Impro Fluidtek motors. Straight oils can be used but may require VI (viscosity index) improvers depending on the operating temperature range of the system. Other water based and environmentally friendly oils may be used, but service life of the motor and other components in the system may be significantly shortened. Before using any type of fluid, consult the fluid requirements for all components in the system for compatibility. Testing under actual operating conditions is the only way to determine if acceptable service life will be achieved.

FLUID VISCOSITY & FILTRATION

Fluids with a viscosity between 20 - 43 cSt [100 - 200 S.U.S.] at operating temperature is recommended. Fluid temperature should also be maintained below 85°C [180° F]. It is also suggested that the type of pump and its operating specifications be taken into account when choosing a fluid for the system. Fluids with high viscosity can cause cavitation at the inlet side of the pump. Systems that operate over a wide range of temperatures may require viscosity improvers to provide acceptable fluid performance.

Impro Fluidtek recommends maintaining an oil cleanliness level of ISO 17-14 or better.

INSTALLATION & START-UP

When installing an Impro Fluidtek motor it is important that the mounting flange of the motor makes full contact with the mounting surface of the application. Mounting hardware of the appropriate grade and size must be used. Hubs, pulleys, sprockets and couplings must be properly aligned to avoid inducing excessive thrust or radial loads. Although the output device must fit the shaft snug, a hammer should never be used to install any type of output device onto the shaft. The port plugs should only be removed from the motor when the system connections are ready to be made. To avoid contamination, remove all matter from around the ports of the motor and the threads of the fittings. Once all system connections are made, it is recommended that the motor be run-in for 15-30 minutes at no load and half speed to remove air from the hydraulic system.

MOTOR PROTECTION

Over-pressurization of a motor is one of the primary causes of motor failure. To prevent these situations, it is necessary to provide adequate relief protection for a motor based on the pressure ratings for that particular model. For systems that may experience overrunning conditions, special precautions must be taken. In an overrunning condition, the motor functions as a pump and attempts to convert kinetic energy into hydraulic energy. Unless the system is properly

configured for this condition, damage to the motor or system can occur. To protect against this condition a counterbalance valve or relief cartridge must be incorporated into the circuit to reduce the risk of over-pressurization. If a relief cartridge is used, it must be installed upline of the motor, if not in the motor, to relieve the pressure created by the over-running motor. To provide proper motor protection for an over-running load application, the pressure setting of the pressure relief valve must not exceed the intermittent rating of the motor.

HYDRAULIC MOTOR SAFETY PRECAUTION

A hydraulic motor must not be used to hold a suspended load. Due to the necessary internal tolerances, all hydraulic motors will experience some degree of creep when a load induced torque is applied to a motor at rest. All applications that require a load to be held must use some form of mechanical brake designed for that purpose.

MOTOR/BRAKE PRECAUTION

Caution! - Impro Fluidtek motor/brakes are intended to operate as static or parking brakes. System circuitry must be designed to bring the load to a stop before applying the brake.

Caution! - Because it is possible for some large displacement motors to overpower the brake, it is critical that the maximum system pressure be limited for these applications. Failure to do so could cause serious injury or death. When choosing a motor/brake for an application, consult the performance chart for the series and displacement chosen for the application to verify that the maximum operating pressure of the system will not allow the motor to produce more torque than the maximum rating of the brake. Also, it is vital that the system relief be set low enough to insure that the motor is not able to overpower the brake.

To ensure proper operation of the brake, a separate case drain back to tank must be used. Use of the internal drain option is not recommended due to the possibility of return line pressure spikes. A simple schematic of a system utilizing a motor/brake is shown on page 5. Although maximum brake release pressure may be used for an application, a 34 bar [500 psi] pressure reducing valve is recommended to promote maximum life for the brake release piston seals. However, if a pressure reducing valve is used in a system which has case drain back pressure, the pressure reducing valve should be set to 34 bar [500 psi] over the expected case pressure to ensure full brake release. To achieve proper brake release operation, it is necessary to bleed out any trapped air and fill brake release cavity and hoses before all connections are tightened. To facilitate this operation, all motor/brakes feature two release ports. One or both of these ports may be used to release the brake in the

OPERATING RECOMMENDATIONS & MOTOR CONNECTIONS

MOTOR/BRAKE PRECAUTION (continued)

unit. Motor/brakes should be configured so that the release ports are near the top of the unit in the installed position.

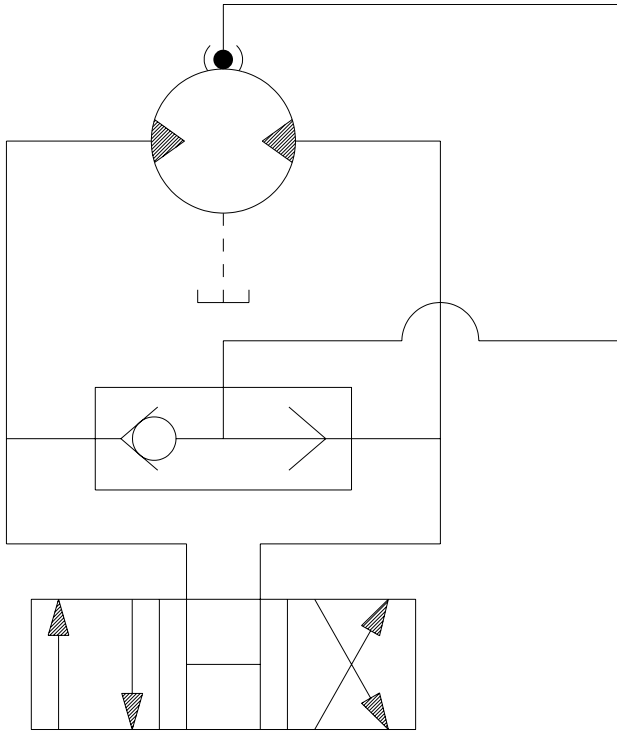

TYPICAL MOTOR/BRAKE SCHEMATIC

Once all system connections are made, one release port must be opened to atmosphere and the brake release line carefully charged with fluid until all air is removed from the line and motor/brake release cavity. When this has been accomplished the port plug or secondary release line must be reinstalled. In the event of a pump or battery failure, an external pressure source may be connected to the brake release port to release the brake, allowing the machine to be moved.

► NOTE: It is vital that all operating recommendations be followed. Failure to do so could result in injury or death.

MOTOR CIRCUITS

There are two common types of circuits used for connecting multiple numbers of motors – series connection and parallel connection.

SERIES CONNECTION

When motors are connected in series, the outlet of one motor is connected to the inlet of the next motor. This allows the full pump flow to go through each motor and provide maximum speed. Pressure and torque are distributed between the motors based on the load each motor is subjected to. The maximum system pressure must be no greater than the maximum inlet pressure of the first motor. The allowable back pressure rating for a motor must also be considered. In some series circuits the motors must have an external case drain connected. A series connection is desirable when it is important for all the motors to run the same speed such as on a long line conveyor.

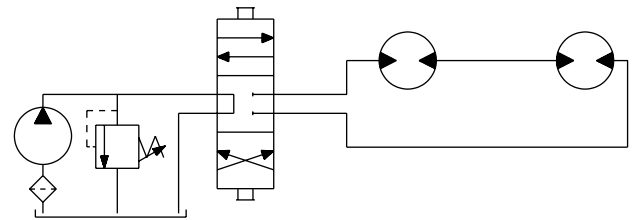

SERIES CIRCUIT

PARALLEL CONNECTION

In a parallel connection all of the motor inlets are connected. This makes the maximum system pressure available to each motor allowing each motor to produce full torque at that pressure. The pump flow is split between the individual motors according to their loads and displacements. If one motor has no load, the oil will take the path of least resistance and all the flow will go to that one motor. The others will not turn. If this condition can occur, a flow divider is recommended to distribute the oil and act as a differential.

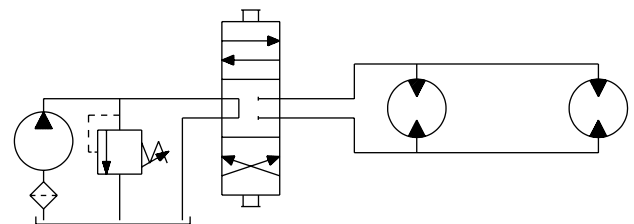

PARALLEL CIRCUIT

► NOTE: The motor circuits shown above are for illustration purposes only. Components and circuitry for actual applications may vary greatly and should be chosen based on the application.

PRODUCT TESTING

Performance testing is the critical measure of a motor's ability to convert flow and pressure into speed and torque. All product testing is conducted using an Impro Fluidtek state of the art test facility. This facility utilizes fully automated test equipment and custom designed software to provide accurate, reliable test data. Test routines are standardized, including test stand calibration and stabilization of fluid temperature and viscosity, to provide consistent data. The example below provides an explanation of the values pertaining to each heading on the performance chart.

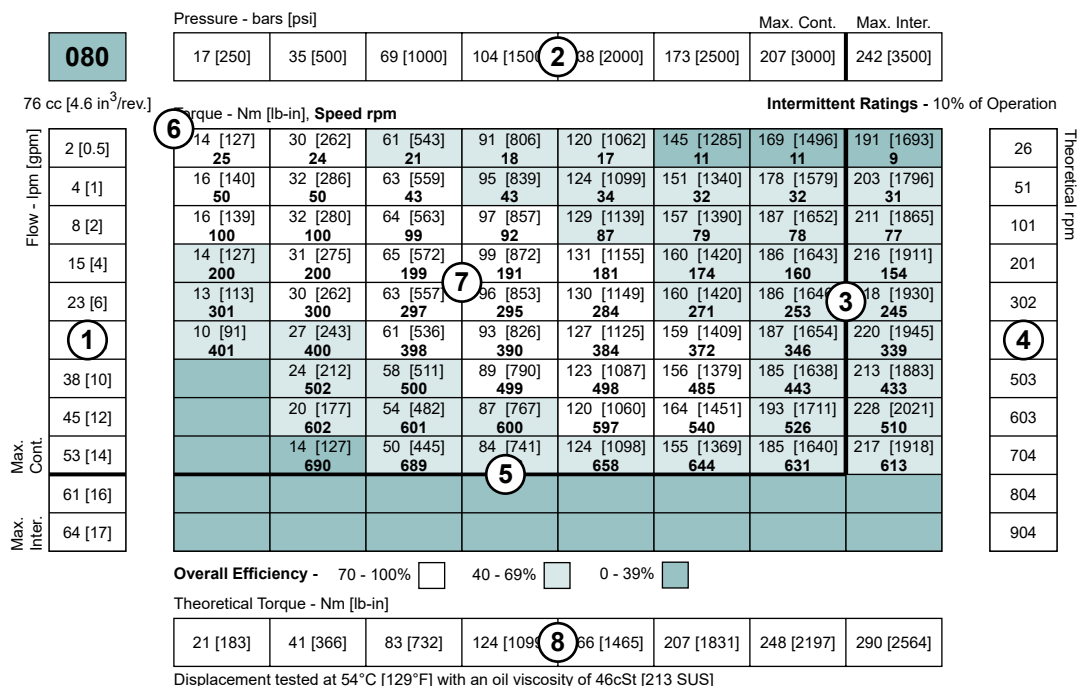

- Flow represents the amount of fluid passing through the motor during each minute of the test.
- Pressure refers to the measured pressure differential between the inlet and return ports of the motor during the test.
- The maximum continuous pressure rating and maximum intermittent pressure rating of the motor are separated by the dark lines on the chart.
- Theoretical RPM represents the RPM that the motor would produce if it were 100% volumetrically efficient. Measured RPM divided by the theoretical RPM give the actual volumetric efficiency of the motor.
- The maximum continuous flow rating and maximum intermittent flow rating of the motor are separated by the dark line on the chart.
- Performance numbers represent the actual torque and speed generated by the motor based on the corresponding input pressure and flow. The numbers on the top row indicate torque as measured in Nm [lb-in], while the bottom number represents the speed of the output shaft.
- Areas within the white shading represent maximum motor efficiencies.
- Theoretical Torque represents the torque that the motor would produce if it were 100% mechanically efficient. Actual torque divided by the theoretical torque gives the actual mechanical efficiency of the motor.

ALLOWABLE BEARING & SHAFT LOADING

This catalog provides curves showing allowable radial loads at points along the longitudinal axis of the motor. They are dimensioned from the mounting flange. Two capacity curves for the shaft and bearings are shown. A vertical line through the centerline of the load drawn to intersect the x-axis intersects the curves at the load capacity of the shaft and of the bearing.

In the example below the maximum radial load bearing rating is between the internal roller bearings illustrated with a solid line. The allowable shaft rating is shown with a dotted line.

The bearing curves for each model are based on laboratory analysis and testing results constructed at Impro Fluidtek. The shaft loading is based on a 3:1 safety factor and 330 Kpsi tensile strength. The allowable load is the lower of the curves at a given point. For instance, one inch in front of the mounting flange the bearing capacity is lower than the shaft capacity. In this case, the bearing is the limiting load. The motor user needs to determine which series of motor to use based on their application knowledge.

ISO 281 RATINGS VS. MANUFACTURERS RATINGS

Published bearing curves can come from more than one type of analysis. The ISO 281 bearing rating is an international standard for the dynamic load rating of roller bearings. The rating is for a set load at a speed of 33 1/3 RPM for 500 hours (1 million revolutions). The standard was established to allow consistent comparisons of similar bearings between manufacturers. The ISO 281 bearing ratings are based solely on the physical characteristics of the bearings, removing any manufacturers specific safety factors or empirical data that influences the ratings.

Manufacturers' ratings are adjusted by diverse and systematic laboratory investigations, checked constantly with feedback from practical experience. Factors taken into account that affect bearing life are material, lubrication, cleanliness of the lubrication, speed, temperature, magnitude of the load and the bearing type.

The operating life of a bearing is the actual life achieved by the bearing and can be significantly different from the calculated life. Comparison with similar applications is the most accurate method for bearing life estimations.

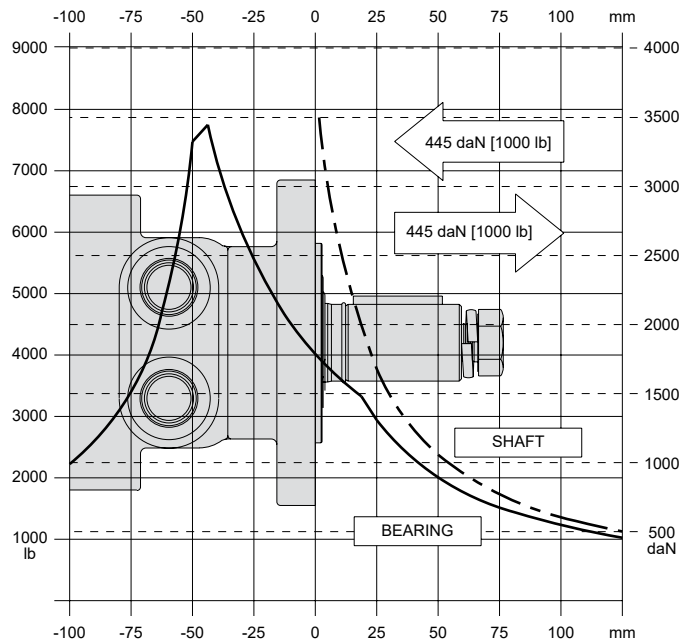

EXAMPLE LOAD RATING FOR MECHANICALLY RETAINED NEEDLE ROLLER BEARINGS

Bearing Life $L_{10} = (C/P)^p [10^6 \text{ revolutions}]$

L_{10} = nominal rating life

C = dynamic load rating

P = equivalent dynamic load

Life Exponent $P = 10/3$ for needle bearings

BEARING LOAD MULTIPLICATION FACTOR TABLE			
RPM	FACTOR	RPM	FACTOR
50	1.23	500	0.62
100	1.00	600	0.58
200	0.81	700	0.56
300	0.72	800	0.50
400	0.66		

VEHICLE DRIVE CALCULATIONS

When selecting a wheel drive motor for a mobile vehicle, a number of factors concerning the vehicle must be taken into consideration to determine the required maximum motor RPM, the maximum torque required and the maximum load each motor must support. The following sections contain the necessary equations to determine this criteria. An example is provided to illustrate the process.

Sample application (vehicle design criteria)

vehicle description..... 4 wheel vehicle
 vehicle drive.....2 wheel drive
 GVW1,500lbs.
 weight over each drive wheel 425 lbs.
 rolling radius of tires 16 in.
 desired acceleration0-5 mph in 10 sec.
 top speed..... 5 mph
 gradability.....20%
 worst working surface..... poor asphalt

To determine maximum motor speed

$$\text{RPM} = \frac{2.65 \times \text{KPH} \times G}{r_m} \quad \text{RPM} = \frac{168 \times \text{MPH} \times G}{r_i}$$

Where:

MPH = max. vehicle speed (miles/hr)
 KPH = max. vehicle speed (kilometers/hr)
 r_i = rolling radius of tire (inches)
 G = gear reduction ratio (if none, G = 1)
 r_m = rolling radius of tire (meters)

Example $\text{RPM} = \frac{168 \times 5 \times 1}{16} = 52.5$

To determine maximum torque requirement of motor

To choose a motor(s) capable of producing enough torque to propel the vehicle, it is necessary to determine the Total Tractive Effort (TE) requirement for the vehicle. To determine the total tractive effort, the following equation must be used:

$$\text{TE} = \text{RR} + \text{GR} + \text{FA} + \text{DP} \text{ (lbs or N)}$$

Where:

TE = Total tractive effort
 RR = Force necessary to overcome rolling resistance
 GR = Force required to climb a grade
 FA = Force required to accelerate
 DP = Drawbar pull required

The components for this equation may be determined using the following steps:

Step One: Determine Rolling Resistance

Rolling Resistance (RR) is the force necessary to propel a vehicle over a particular surface. It is recommended that the worst possible surface type to be encountered by the vehicle be factored into the equation.

$$\text{RR} = \frac{\text{GVW}}{1000} \times R \text{ (lb or N)}$$

Where:

GVW = gross (loaded) vehicle weight (lb or kg)
 R = surface friction (value from Table 1)

Example $\text{RR} = \frac{1500}{1000} \times 22 \text{ lbs} = 33 \text{ lbs}$

Table 1

Rolling Resistance	
Concrete (excellent).....	10
Concrete (good).....	15
Concrete (poor).....	20
Asphalt (good).....	12
Asphalt (fair).....	17
Asphalt (poor).....	22
Macadam (good).....	15
Macadam (fair).....	22
Macadam (poor).....	37
Cobbles (ordinary).....	55
Cobbles (poor).....	37
Snow (2 inch).....	25
Snow (4 inch).....	37
Dirt (smooth).....	25
Dirt (sandy).....	37
Mud.....	37 to 150
Sand (soft).....	60 to 150
Sand (dune).....	160 to 300

Step Two: Determine Grade Resistance

Grade Resistance (GR) is the amount of force necessary to move a vehicle up a hill or "grade." This calculation must be made using the maximum grade the vehicle will be expected to climb in normal operation.

To convert incline degrees to % Grade:

$$\% \text{ Grade} = [\tan \text{ of angle (degrees)}] \times 100$$

$$\text{GR} = \frac{\% \text{ Grade}}{100} \times \text{GVW (lb or N)}$$

Example $\text{GR} = \frac{20}{100} \times 1500 \text{ lbs} = 300 \text{ lbs}$

VEHICLE DRIVE CALCULATIONS

Step Three: Determine Acceleration Force

Acceleration Force (FA) is the force necessary to accelerate from a stop to maximum speed in a desired time.

$$FA = \frac{MPH \times GVW \text{ (lb)}}{22 \times t} \qquad FA = \frac{KPH \times GVW \text{ (N)}}{35.32 \times t}$$

Where:

t = time to maximum speed (seconds)

Example $FA = \frac{5 \times 1500 \text{ lbs}}{22 \times 10} = 34 \text{ lbs}$

Step Four: Determine Drawbar Pull

Drawbar Pull (DP) is the additional force, if any, the vehicle will be required to generate if it is to be used to tow other equipment. If additional towing capacity is required for the equipment, repeat steps one through three for the towable equipment and sum the totals to determine DP.

Step Five: Determine Total Tractive Effort

The Tractive Effort (TE) is the sum of the forces calculated in steps one through three above. On low speed vehicles, wind resistance can typically be neglected. However, friction in drive components may warrant the addition of 10% to the total tractive effort to insure acceptable vehicle performance.

$$TE = RR + GR + FA + DP \text{ (lb or N)}$$

Example $TE = 33 + 300 + 34 + 0 \text{ (lbs)} = 367 \text{ lbs}$

Step Six: Determine Motor Torque

The Motor Torque (T) required per motor is the Total Tractive Effort divided by the number of motors used on the machine. Gear reduction is also factored into account in this equation.

$$T = \frac{TE \times ri}{M \times G} \text{ lb-in per motor} \qquad T = \frac{TE \times rm}{M \times G} \text{ Nm per motor}$$

Where:

M = number of driving motors

Example $T = \frac{367 \times 16}{2 \times 1} \text{ lb-in/motor} = 2936 \text{ lb-in}$

Step Seven: Determine Wheel Slip

To verify that the vehicle will perform as designed in regards to tractive effort and acceleration, it is necessary to calculate wheel slip (TS) for the vehicle. In special cases, wheel slip may actually be desirable to prevent hydraulic system overheating and component breakage should the vehicle become stalled.

$$TS = \frac{W \times f \times ri}{G} \qquad TS = \frac{W \times f \times rm}{G}$$

(lb-in per motor) (N-m per motor)

Where:

f = coefficient of friction (see table 2)

W = loaded vehicle weight over driven wheel (lb or N)

Example $TS = \frac{425 \times .06 \times 16}{1} \text{ lb-in/motor} = 4080 \text{ lbs}$

Table 2

Coefficient of friction (f)	
Steel on steel.....	0.3
Rubber tire on dirt.....	0.5
Rubber tire on a hard surface	0.6 - 0.8
Rubber tire on cement.....	0.7

To determine radial load capacity requirement of motor

When a motor used to drive a vehicle has the wheel or hub attached directly to the motor shaft, it is critical that the radial load capabilities of the motor are sufficient to support the vehicle. After calculating the Total Radial Load (RL) acting on the motors, the result must be compared to the bearing/shaft load charts for the chosen motor to determine if the motor will provide acceptable load capacity and life.

$$RL = \sqrt{W^2 + \left(\frac{T}{ri}\right)^2} \text{ lb} \qquad RL = \sqrt{W^2 + \left(\frac{T}{rm}\right)^2} \text{ kg}$$

Example $RL = \sqrt{425^2 + \left(\frac{2936}{16}\right)^2} = 463 \text{ lbs}$

Once the maximum motor RPM, maximum torque requirement, and the maximum load each motor must support have been determined, these figures may then be compared to the motor performance charts and to the bearing load curves to choose a series and displacement to fulfill the motor requirements for the application.

INDUCED SIDE LOAD

In many cases, pulleys or sprockets may be used to transmit the torque produced by the motor. Use of these components will create a torque induced side load on the motor shaft and bearings. It is important that this load be taken into consideration when choosing a motor with sufficient bearing and shaft capacity for the application.

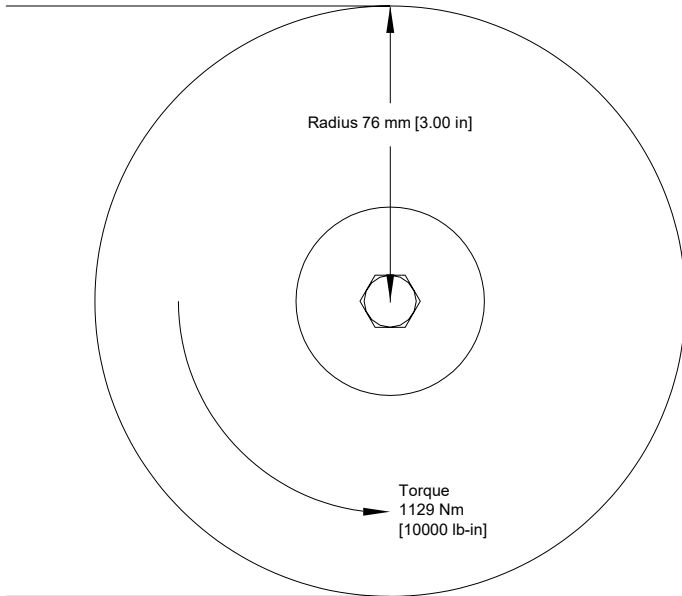

To determine the side load, the motor torque and pulley or sprocket radius must be known. Side load may be calculated using the formula below. The distance from the pulley/sprocket centerline to the mounting flange of the motor must also be determined. These two figures may then be compared to the bearing and shaft load curve of the desired motor to determine if the side load falls within acceptable load ranges.

$$\text{Side Load} = \frac{\text{Torque}}{\text{Radius}}$$

$$\text{Side Load} = 14855 \text{ Nm [3333 lbs]}$$

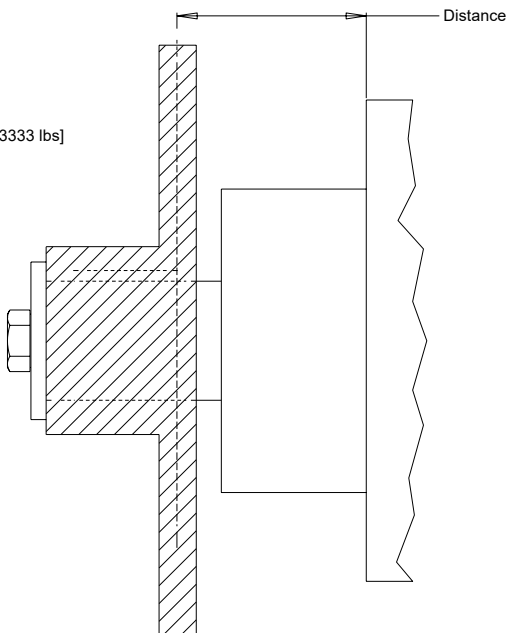

HYDRAULIC EQUATIONS

Multiplication Factor	Abbrev.	Prefix
10 ¹²	T	tera
10 ⁹	G	giga
10 ⁶	M	mega
10 ³	K	kilo
10 ²	h	hecto
10 ¹	da	deka
10 ⁻¹	d	deci
10 ⁻²	c	centi
10 ⁻³	m	milli
10 ⁻⁶	u	micro
10 ⁻⁹	n	nano
10 ⁻¹²	p	pico
10 ⁻¹⁵	f	femto
10 ⁻¹⁸	a	atto

Theo. Speed (RPM) =

$$\frac{1000 \times \text{LPM}}{\text{Displacement (cm}^3\text{/rev)}} \quad \text{or} \quad \frac{231 \times \text{GPM}}{\text{Displacement (in}^3\text{/rev)}}$$

Theo. Torque (lb-in) =

$$\frac{\text{Bar} \times \text{Disp. (cm}^3\text{/rev)}}{20 \pi} \quad \text{or} \quad \frac{\text{PSI} \times \text{Displacement (in}^3\text{/rev)}}{6.28}$$

Power In (HP) =

$$\frac{\text{Bar} \times \text{LPM}}{600} \quad \text{or} \quad \frac{\text{PSI} \times \text{GPM}}{1714}$$

Power Out (HP) =

$$\frac{\text{Torque (Nm)} \times \text{RPM}}{9543} \quad \text{or} \quad \frac{\text{Torque (lb-in)} \times \text{RPM}}{63024}$$

SHAFT NUT INFORMATION

35MM TAPERED SHAFTS
M24 x 1.5 Thread

A Slotted Nut

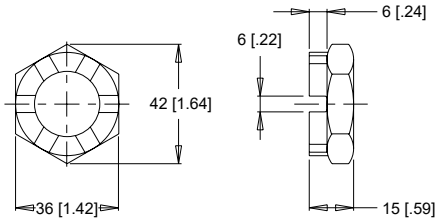

Torque Specifications: 32.5 daNm [240 ft.lb.]

PRECAUTION

The tightening torques listed with each nut should only be used as a guideline. Hubs may require higher or lower tightening torque depending on the material. Consult the hub manufacturer to obtain recommended tightening torque. To maximize torque transfer from the shaft to the hub, and to minimize the potential for shaft breakage, a hub with sufficient thickness must fully engage the taper length of the shaft.

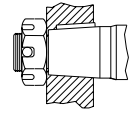

incorrect

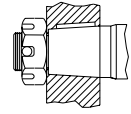

correct

1" TAPERED SHAFTS
3/4-28 Thread

A Slotted Nut

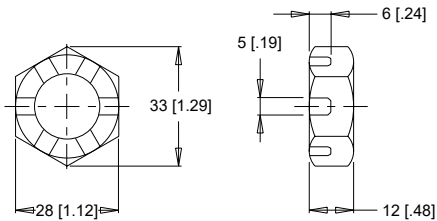

Torque Specifications: 20 - 23 daNm [150 - 170 ft.lb.]

B Lock Nut

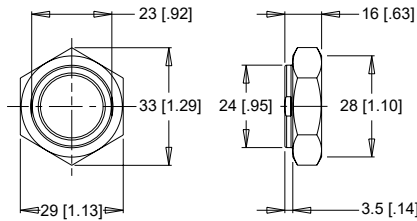

Torque Specifications: 24 - 27 daNm [180 - 200 ft.lb.]

C Solid Nut

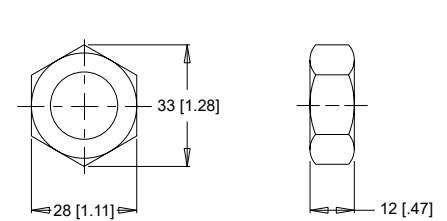

Torque Specifications: 20 - 23 daNm [150 - 170 ft.lb.]

1-1/4" TAPERED SHAFTS
1-20 Thread

A Slotted Nut

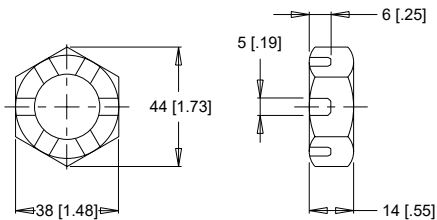

Torque Specifications: 38 daNm [280 ft.lb.] Max.

B Lock Nut

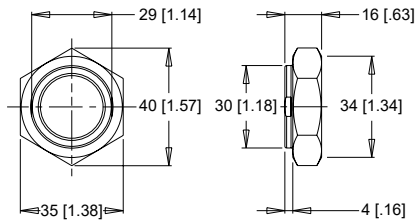

Torque Specifications: 33 - 42 daNm [240 - 310 ft.lb.]

C Solid Nut

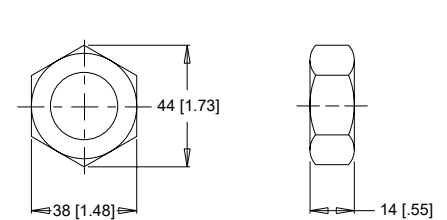

Torque Specifications: 38 daNm [280 ft.lb.] Max.

1-3/8" & 1-1/2" TAPERED SHAFTS
1 1/8-18 Thread

A Slotted Nut

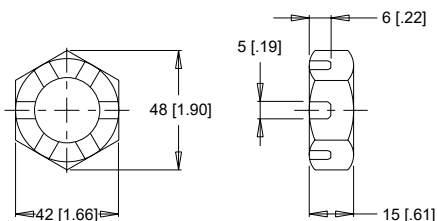

Torque Specifications: 41 - 54 daNm [300 - 400 ft.lb.]

B Lock Nut

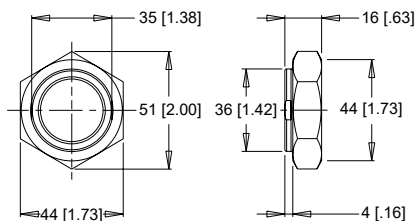

Torque Specifications: 34 - 48 daNm [250 - 350 ft.lb.]

C Solid Nut

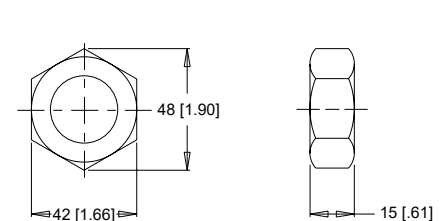

Torque Specifications: 41 - 54 daNm [300 - 400 ft.lb.]

SPEED SENSORS

Impro Fluidtek offers both single and dual element speed sensor options providing a number of benefits to users by incorporating the latest advancements in sensing technology and materials. The single element sensors provide 50 pulses per revolution with the dual element providing 100 pulses per revolution.” Higher resolution is especially beneficial for slow speed applications, where more information is needed for smooth and accurate control. The dual sensor option also provides a direction signal allowing end-users to monitor the direction of shaft rotation.

Unlike competitive designs that breach the high pressure area of the motor to add the sensor, the Impro Fluidtek speed sensor option utilizes an add-on flange to locate all sensor components outside the high pressure operating environment. This eliminates the potential leak point common to competitive designs. Many improvements were made to the sensor flange including changing the material from cast iron to acetal resin, incorporating a Buna-N shaft seal internal to the flange, and providing a grease zerk, which allows the user to fill the sensor cavity with grease. These improvements enable the flange to withstand the rigors of harsh environments.

Another important feature of the new sensor flange is that it is self-centering, which allows it to remain concentric to the magnet rotor. This produces a consistent mounting location for the new sensor module, eliminating the need to adjust

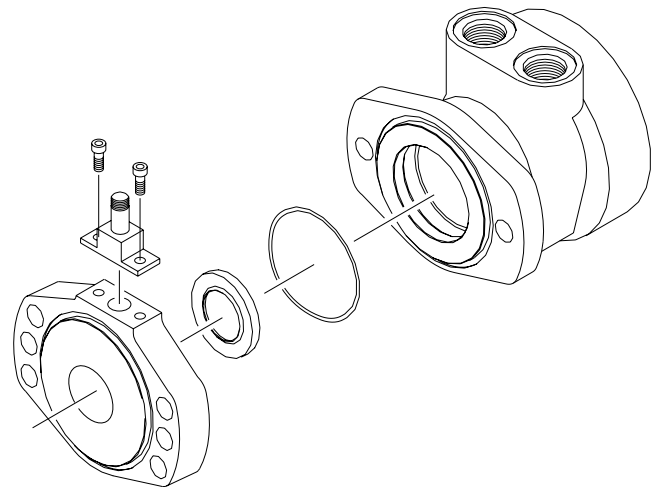

the air gap between the sensor and magnet rotor. The o-ring sealed sensor module attaches to the sensor flange with two small screws, allowing the sensor to be serviced or upgraded in the field in under one minute. This feature is especially valuable for mobile applications where machine downtime is costly. The sensor may also be serviced without exposing the hydraulic circuit to the atmosphere. Another advantage of the self-centering flange is that it allows users to rotate the sensor to a location best suited to their application. This feature is not available on competitive designs, which fix the sensor in one location in relationship to the motor mounting flange.

FEATURES / BENEFITS

- Grease fitting allows sensor cavity to be filled with grease for additional protection.
- Internal extruder seal protects against environmental elements.
- M12 or weatherpack connectors provide installation flexibility.
- Dual element sensor provides up to 100 pulses per revolution and directional sensing.
- Modular sensor allows quick and easy servicing.
- Acetal resin flange is resistant to moisture, chemicals, oils, solvents and greases.
- Self-centering design eliminates need to set magnet-to-sensor air gap.
- Protection circuitry

SENSOR OPTIONS

Z - 4-pin M12 male connector

This option has 50 pulses per revolution on all series. This option will not detect direction.

Y - 3-pin male weatherpack connector*

This option has 50 pulses per revolution on all series. This option will not detect direction.

X - 4-pin M12 male connector

This option has 100 pulses per revolution on all series. This option will detect direction.

W - 4-pin male weatherpack connector*

This option has 100 pulses per revolution on all series. This option will detect direction.

*These options include a 610mm [2 ft] cable.

SPEED SENSORS

SINGLE ELEMENT SENSOR - Y & Z

Supply voltages..... 7.5-24 Vdc
 Maximum output off voltage..... V
 Maximum continuous output current..... < 25 ma
 Signal levels (low, high)..... 0.8 to supply voltage
 Operating Temp-30°C to 83°C [-22°F to 181°F]

DUAL ELEMENT SENSOR - X & W

Supply voltages..... 7.5-18 Vdc
 Maximum output off voltage..... V
 Maximum continuous output current..... < 20 ma
 Signal levels (low, high)..... 0.8 to supply voltage
 Operating Temp-30°C to 83°C [-22°F to 181°F]

SENSOR CONNECTORS

Z Option

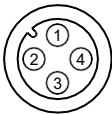

PIN

1	positive	brown or red
2	n/a	white
3	negative	blue
4	pulse out	black

X Option

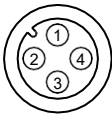

PIN

1	positive	brown or red
2	direction out	white
3	negative	blue
4	pulse out	black

Y Option

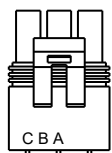

PIN

A	positive	brown or red
B	negative	blue
C	pulse out	black
D	n/a	white

W Option

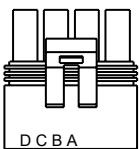

PIN

A	positive	brown or red
B	negative	blue
C	pulse out	black
D	direction out	white

PROTECTION CIRCUITRY

The single element sensor has been improved and incorporates protection circuitry to avoid electrical damage caused by:

- reverse battery protection
- overvoltage due to power supply spikes and surges (60 Vdc max.)
- power applied to the output lead

The protection circuit feature will help “save” the sensor from damage mentioned above caused by:

- faulty installation wiring or system repair
- wiring harness shorts/opens due to equipment failure or harness damage resulting from accidental conditions (i.e. severed or grounded wire, ice, etc.)
- power supply spikes and surges caused by other electrical/electronic components that may be intermittent or damaged and “loading down” the system.

While no protection circuit can guarantee against any and all fault conditions. The single element sensor from Impro Fluidtek with protection circuitry is designed to handle potential hazards commonly seen in real world applications.

Unprotected versions are also available for operation at lower voltages down to 4.5V.

FREE TURNING ROTOR

The ‘AC’ option or “Free turning” option refers to a specially prepared rotor assembly. This rotor assembly has increased clearance between the rotor tips and rollers allowing it to turn more freely than a standard rotor assembly. For spool valve motors, additional clearance is also provided between the shaft and housing bore. The ‘AC’ option is available for all motor series and displacements.

There are several applications and duty cycle conditions where ‘AC’ option performance characteristics can be beneficial. In continuous duty applications that require high flow/high rpm operation, the benefits are twofold. The additional clearance helps to minimize internal pressure drop at high flows. This clearance also provides a thicker oil film at metal to metal contact areas and can help extend the life of the motor in high rpm or even over speed conditions. The ‘AC’ option should be considered for applications that require continuous operation above 57 LPM [15 GPM] and/or 300 rpm. Applications that are subject to pressure spikes due to frequent reversals or shock loads can also benefit by specifying the ‘AC’ option. The additional clearance serves to act as a buffer against spikes, allowing them to be bypassed through the motor rather than being absorbed and transmitted through the drive link to the output shaft. The trade-off for achieving these benefits is a slight loss of volumetric efficiency at high pressures.

INTERNAL DRAIN

The internal drain is standard on all WD, WP, WR, and WS360. Typically, a separate drain line must be installed to direct case leakage of the motor back to the reservoir when using, WS365/366. However, the internal drain option eliminates the need for a separate drain line through the installation of two check valves in the motor. This simplifies plumbing requirements for the motor.

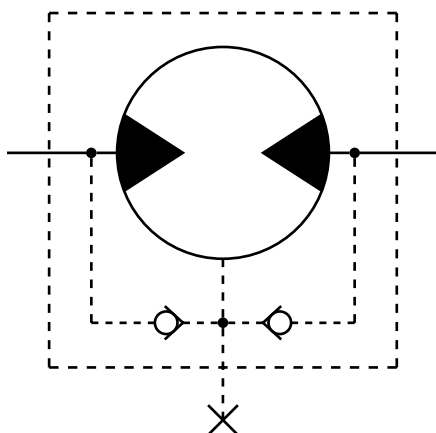

The two check valves connect the case area of the motor to each port of the endcover. During normal motor operation, pressure in the input and return lines of the motor close the check valves. However, when the pressure in the case of the motor is greater than that of the return line, the check valve between the case and low pressure line opens, allowing the case leakage to flow into the return line. Since the operation of the check valves is dependent upon a pressure differential, the internal drain option operates in either direction of motor rotation.

Although this option can simplify many motor installations, precautions must be taken to insure that return line pressure remains below allowable levels (see table below) to insure proper motor operation and life. If return line pressure is higher than allowable, or experiences pressure spikes, this pressure may feed back into the motor, possibly causing catastrophic seal failure. Installing motors with internal drains in series is not recommended unless overall pressure drop over all motors is below the maximum allowable backpressure as listed in the chart below. If in doubt, contact your authorized Impro Fluidtek representative.

MAXIMUM ALLOWABLE BACK PRESSURE		
Series	Cont. bar [psi]	Inter. bar [psi]
Brakes	34 [500]	34 [500]

HYDRAULIC DECLUTCH

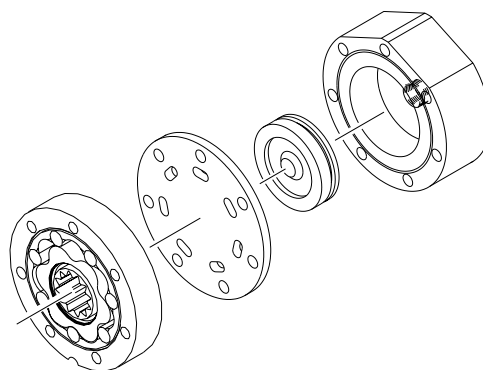

The declutch or 'AE' option, available on the RE and CE Series motors, has been specifically designed for applications requiring the motor to have the ability to "freewheel" when not pressurized. By making minor changes to internal components, the torque required to turn the output shaft is minimal. Selection of this option allows freewheeling speeds up to 1,000 RPM* depending on the displacement of the motor and duty cycle of the application.

To enable the motor to perform this function, the standard rotor assembly is replaced with a freeturn rotor assembly. Next, the standard balance plate and endcover is replaced with a special wear plate and ported endcover. The wear plate features seven holes that connect the stator pockets to each other. The ported endcover features a movable piston capable of sealing the seven holes in the wear plate.

When standard motor function is required, pressure is supplied to the endcover port, moving the piston against the wear plate. This action seals the seven holes allowing the motor to function as normal. However, when pressure is removed from the endcover port, the pressure created by the turning rotor assembly pushes the piston away from the wear plate, opening the rotor pockets to each other. In this condition, oil may circulate freely within the rotor and endcover assemblies, allowing the rotor assembly to rotate freely within the motor.

This option is especially useful in applications ranging from winch drives to towable wheel drives. Depending on the valves and hydraulic circuitry, operation of the freewheel function may be manually or automatically selected. A basic schematic is shown to the right.

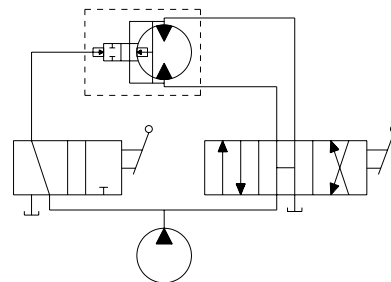

► The 1,000 RPM rating was based on smaller displacement options with forced flow flushing through the motor to provide cooling.

VALVE CAVITY

The valve cavity option provides a cost effective way to incorporate a variety of cartridge valves integral to the motor. The valve cavity is a standard 10 series 2-way cavity that accepts numerous cartridge valves, including over-running check valves, relief cartridges, flow control valves, pilot operated check fuses, and high pressure shuttle valves. Installation of a relief cartridge into the cavity provides an extra margin of safety for applications encountering frequent pressure spikes. Relief cartridges from 69 to 207 bar [1000 to 3000 psi] may also be factory installed.

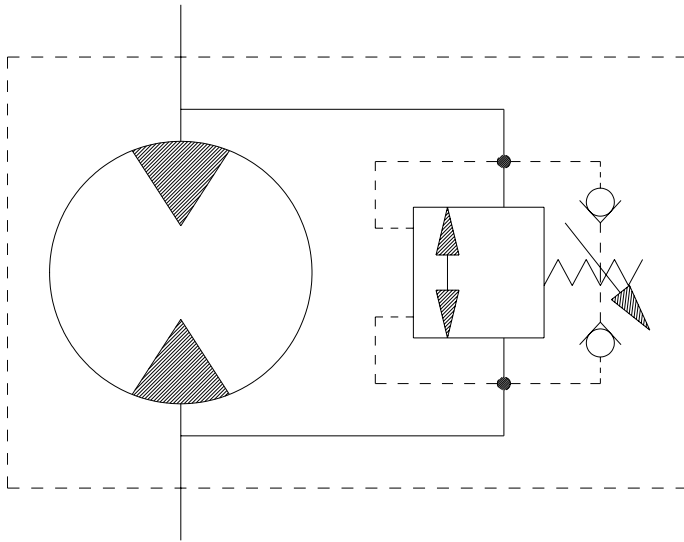

For basic systems with fixed displacement pumps, either manual or motorized flow control valves may be installed into the valve cavity to provide a simple method for controlling motor speed. It is also possible to incorporate the speed sensor option and a programmable logic controller with a motorized flow control valve to create a closed loop, fully automated speed control system. For motors with internal brakes, a shuttle valve cartridge may be installed into the cavity to provide a simple, fully integrated method for supplying release pressure to the pilot line to actuate an integral brake. To discuss other alternatives for the valve cavity option, contact an authorized Impro Fluidtek distributor.

SLINGER SEAL

Slinger seals are available on select series offered by Impro Fluidtek. Slinger seals offer extended shaft/shaft seal protection by prevented a buildup of material around the circumference of the shaft which can lead to premature shaft seal failures. The Impro Fluidtek slinger seals are designed to be larger in diameter than competitive products, providing greater surface speed and 'slinging action'.

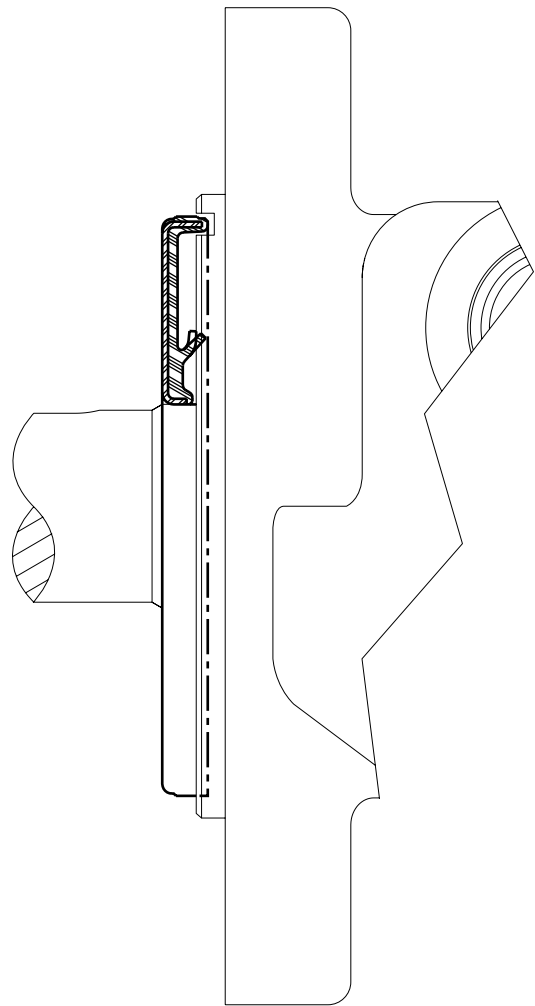

Slinger seals are also available on 4-hole flange mounts on select series. Contact a Impro Fluidtek Customer Service Representative for additional information.

OVERVIEW

The Impro Fluidtek tradition of providing motors that excel in demanding applications continues with the WG series. WG motors provide an exceptionally solid platform for any light-duty application where sideload may present a concern. The WG incorporates our unique rotor design which reduces friction and extends motor life. With displacements ranging from 41 - 404 cm³ [2.5 - 24.4 in³] per revolution and a choice of mounting, shaft, and port options, this motor is made to satisfy a variety of applications. The WG is a perfect fit when you require improved performance and long motor life at an affordable price.

FEATURES / BENEFITS

- Needle Roller Bearing is in optimum location to allow load to be placed as close to the center line of bearing as possible.
- High Pressure Buna® Shaft Seal offers superior seal life and performance and eliminates the need for a case drain.
- Heavy-Duty Drive Link receives full flow lubrication to provide long life.
- Rotor design increases efficiency and life by using roller contact versus solid, sliding contact design.
- Rubber Energized Steel Face Seal does not extrude or melt under high pressure or high temperature.

TYPICAL APPLICATIONS

conveyors, carwashes, positioners, light-duty wheel drives, sweepers, grain augers, spreaders, feed rollers, screw drives, brush drives and more

SERIES DESCRIPTIONS

275/276 - Hydraulic Motor
Standard

277/278 - Hydraulic Motor
Modified Port Locations

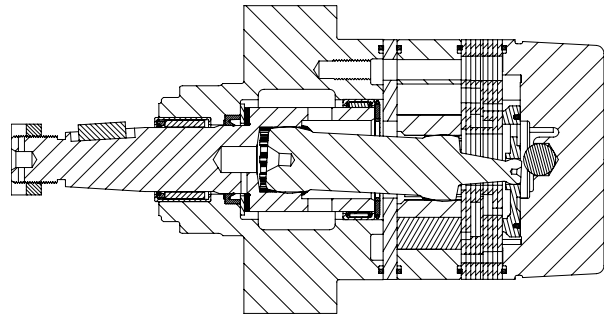

280/281 - Hydraulic Motor
With Larger Dia. Shafts

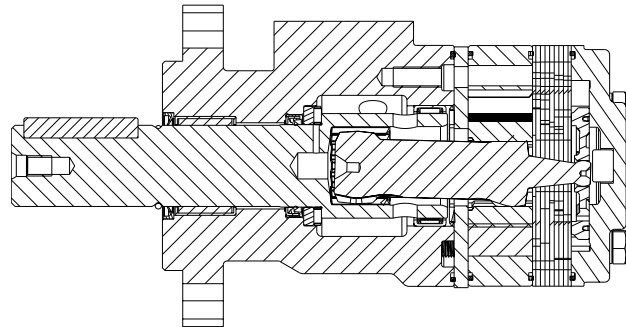

SPECIFICATIONS

CODE	Displacement cm ³ [in ³ /rev]	Max. Speed rpm		Max. Flow lpm [gpm]		Max. Torque Nm [lb-in]		Max. Pressure bar [psi]		
		cont.	inter.	cont.	inter.	cont.	inter.	cont.	inter.	peak
040	41 [2.5]	830	1020	34 [9]	42 [11]	71 [630]	100 [870]	138 [2000]	190 [2750]	207 [3000]
045	44 [2.7]	770	940	34 [9]	42 [11]	78 [685]	108 [955]	138 [2000]	190 [2750]	207 [3000]
060	60 [3.6]	760	950	45 [12]	57 [15]	107 [950]	150 [1320]	138 [2000]	190 [2750]	207 [3000]
070	70 [4.3]	650	810	45 [12]	57 [15]	127 [1120]	176 [1560]	138 [2000]	190 [2750]	207 [3000]
090	88 [5.4]	520	650	45 [12]	57 [15]	162 [1430]	224 [1985]	138 [2000]	190 [2750]	207 [3000]
100	100 [6.1]	450	570	45 [12]	57 [15]	185 [1640]	257 [2275]	138 [2000]	190 [2750]	207 [3000]
130	129 [7.9]	350	440	45 [12]	57 [15]	241 [2135]	334 [2960]	138 [2000]	190 [2750]	207 [3000]
160	161 [9.8]	280	350	45 [12]	57 [15]	304 [2690]	421 [3730]	138 [2000]	190 [2750]	207 [3000]
200	200 [12.2]	220	280	45 [12]	57 [15]	379 [3350]	525 [4650]	138 [2000]	190 [2750]	207 [3000]
230	231 [14.1]	240	330	57 [15]	76 [20]	380 [3380]	529 [4680]	121 [1750]	165 [2400]	200 [2900]
320	322 [19.7]	175	235	57 [15]	76 [20]	458 [4050]	600 [5300]	103 [1500]	134 [1950]	169 [2450]
400	404 [24.4]	140	185	57 [15]	76 [20]	548 [4850]	758 [6710]	100 [1450]	135 [1960]	170 [2460]

► Performance data is typical. Performance of production units varies slightly from one motor to another. Running at intermittent ratings should not exceed 10% of every minute of operation.

DISPLACEMENT PERFORMANCE

040		Pressure - bar [psi]					Max. Cont.		Max. Inter.		
		35 [500]	69 [1000]	104 [1500]	138 [2000]	190 [2750]					
41 cm ³ [2.5 in ³] / rev											
Flow - lpm [gpm]		Torque - Nm [lb-in], Speed rpm					Intermittent Ratings - 10% of Operation				
		13 [117] 37	29 [259] 25	45 [401] 4							
Max. Max. Inter. Cont.	4 [1]	14 [126] 85	31 [276] 72	48 [427] 51	65 [577] 21						93
	8 [2]	15 [134] 179	33 [293] 166	51 [453] 144	69 [612] 113	96 [852] 49					186
	11 [3]	15 [136] 273	34 [299] 260	52 [462] 237	71 [625] 205	98 [869] 138					279
	15 [4]	15 [136] 368	34 [300] 354	52 [464] 330	71 [628] 296	99 [874] 227					372
	19 [5]	15 [134] 462	34 [298] 448	52 [462] 423	71 [626] 388	98 [872] 316					464
	27 [7]	15 [129] 650	33 [291] 636	51 [454] 609	70 [617] 572	97 [861] 493					650
	34 [9]	14 [122] 835	32 [283] 824	50 [445] 796	69 [607] 755	96 [849] 671					835
	42 [11]	13 [115] 1021	31 [276] 1012	49 [437] 982	68 [599] 939						1021
	Overall Efficiency - 70 - 100% <input type="checkbox"/> 40 - 69% <input type="checkbox"/> 0 - 39% <input checked="" type="checkbox"/>										
	Theoretical Torque - Nm [lb-in]										
Rotor Width		22 [198]	45 [396]	67 [595]	90 [793]	123 [1090]					
8.1 [317] mm [in]		Displacement tested at 54°C [129°F] with an oil viscosity of 46cSt [213 SUS]									

045		Pressure - bar [psi]					Max. Cont.		Max. Inter.		
		35 [500]	69 [1000]	104 [1500]	138 [2000]	190 [2750]					
44 cm ³ [2.7 in ³] / rev											
Flow - lpm [gpm]		Torque - Nm [lb-in], Speed rpm					Intermittent Ratings - 10% of Operation				
		15 [131] 34	32 [285] 23	50 [438] 4							
Max. Max. Inter. Cont.	4 [1]	16 [140] 78	34 [303] 66	53 [467] 47	71 [631] 19						86
	8 [2]	17 [148] 165	36 [322] 153	56 [496] 133	76 [669] 104	105 [930] 45					172
	11 [3]	17 [151] 252	37 [328] 240	57 [506] 219	77 [683] 189	107 [950] 127					257
	15 [4]	17 [150] 339	37 [329] 326	57 [508] 304	78 [687] 273	108 [955] 209					343
	19 [5]	17 [147] 426	37 [326] 413	57 [505] 390	77 [685] 358	108 [953] 291					428
	27 [7]	16 [140] 599	36 [318] 586	56 [496] 562	76 [674] 527	106 [942] 455					599
	34 [9]	15 [131] 770	35 [308] 760	55 [485] 734	75 [662] 696	105 [928] 619					770
	42 [11]	14 [121] 942	34 [298] 933	54 [475] 906	74 [652] 866						942
	Overall Efficiency - 70 - 100% <input type="checkbox"/> 40 - 69% <input type="checkbox"/> 0 - 39% <input checked="" type="checkbox"/>										
	Theoretical Torque - Nm [lb-in]										
Rotor Width		24 [215]	49 [430]	73 [645]	97 [860]	134 [1182]					
8.7 [344] mm [in]		Displacement tested at 54°C [129°F] with an oil viscosity of 46cSt [213 SUS]									

► Performance data is typical. Performance of production units varies slightly from one motor to another. Operating at maximum continuous pressure and maximum continuous flow simultaneously is not recommended. For additional information on product testing please refer to page 6.

DISPLACEMENT PERFORMANCE

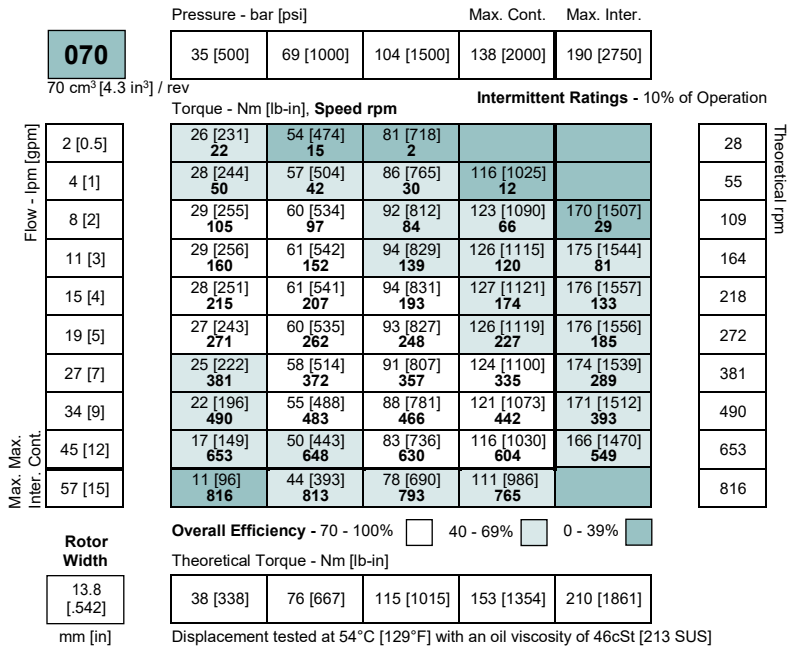
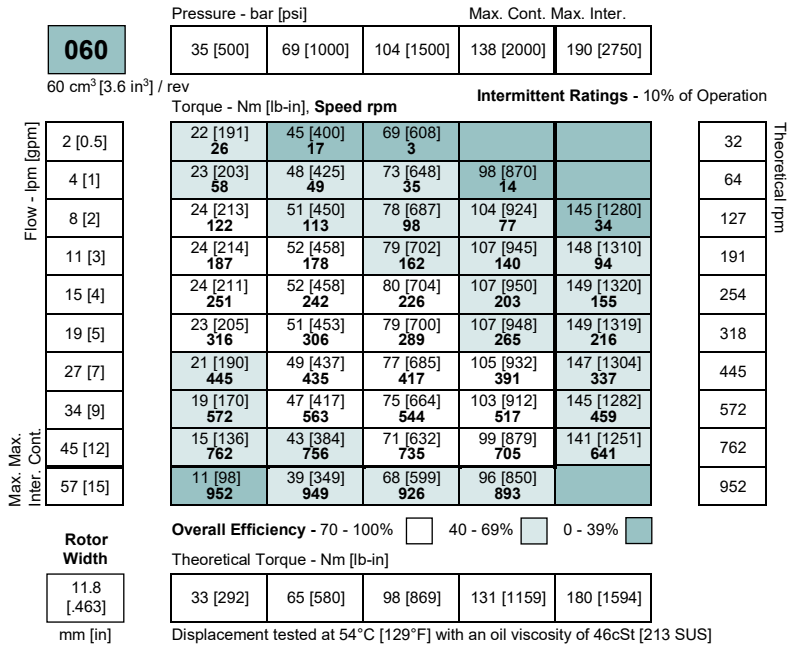

► Performance data is typical. Performance of production units varies slightly from one motor to another. Operating at maximum continuous pressure and maximum continuous flow simultaneously is not recommended. For additional information on product testing please refer to page 6.

DISPLACEMENT PERFORMANCE

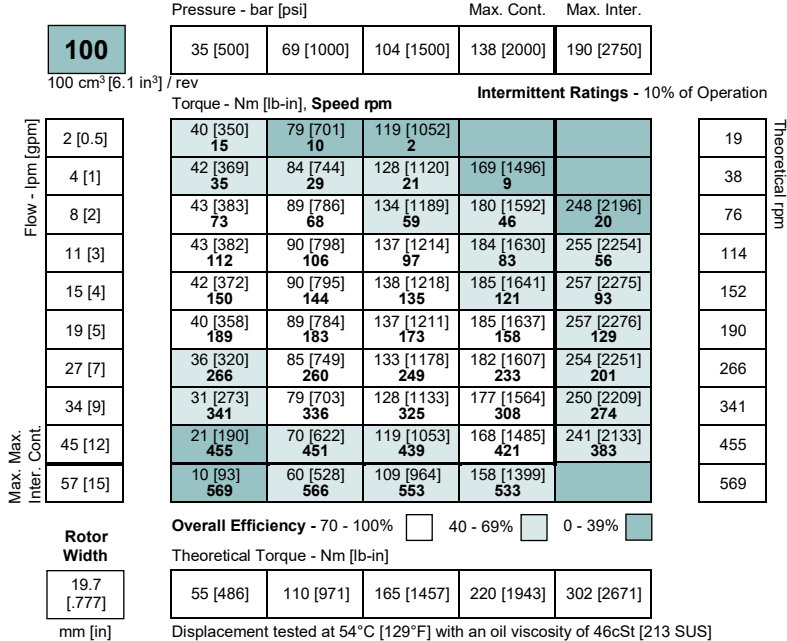
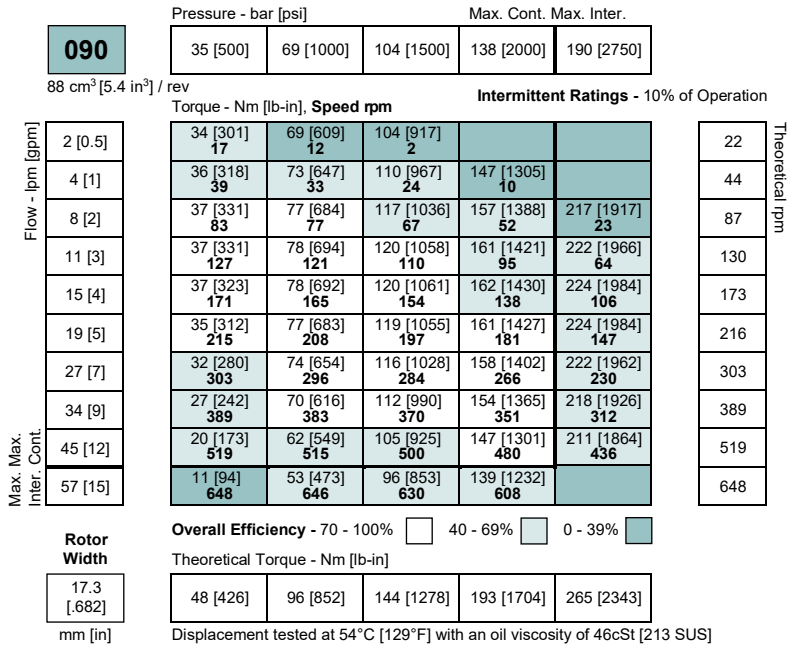

► Performance data is typical. Performance of production units varies slightly from one motor to another. Operating at maximum continuous pressure and maximum continuous flow simultaneously is not recommended. For additional information on product testing please refer to page 6.

DISPLACEMENT PERFORMANCE

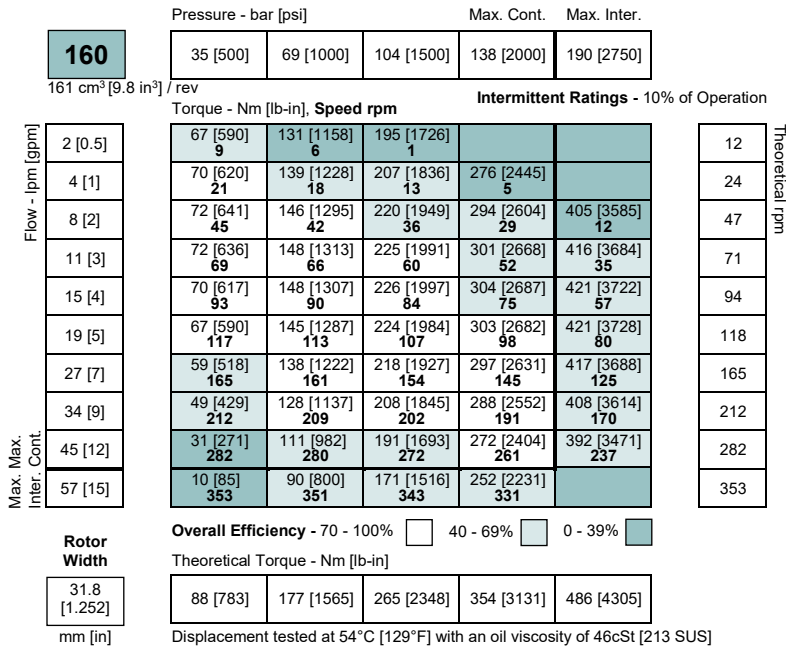
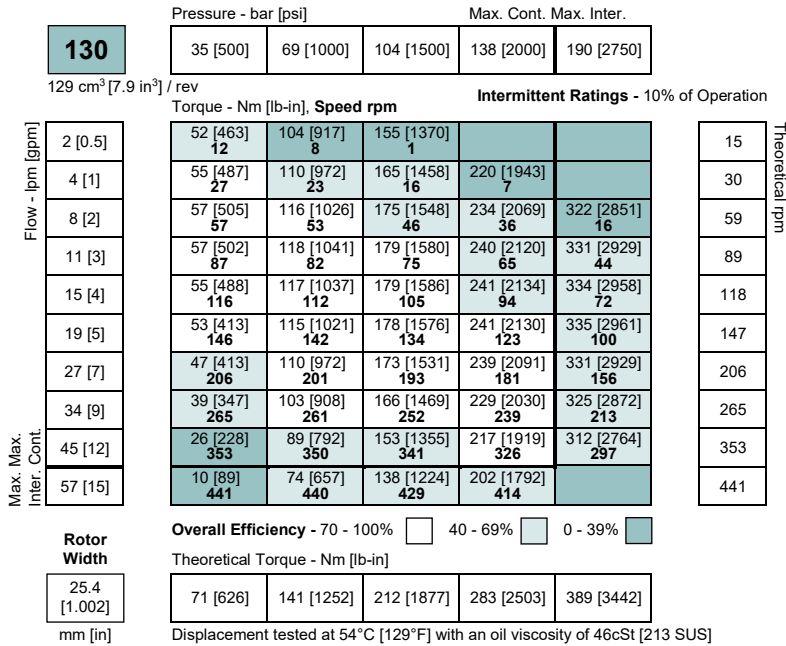

► Performance data is typical. Performance of production units varies slightly from one motor to another. Operating at maximum continuous pressure and maximum continuous flow simultaneously is not recommended. For additional information on product testing please refer to page 6.

DISPLACEMENT PERFORMANCE

		Pressure - bar [psi]				Max. Cont. Max. Inter.	
200		35 [500]	69 [1000]	104 [1500]	138 [2000]	190 [2750]	
200 cm ³ [12.2 in ³] / rev		Torque - Nm [lb-in], Speed rpm				Intermittent Ratings - 10% of Operation	
Flow - lpm [gpm]	2 [0.5]	84 [742] 8	164 [1447] 5	243 [2152] 1			10
	4 [1]	88 [778] 17	173 [1534] 15	259 [2289] 10	344 [3045] 4		19
	8 [2]	91 [804] 37	183 [1617] 34	275 [2430] 29	367 [3244] 23	504 [4464] 10	38
	11 [3]	90 [796] 56	185 [1639] 53	280 [2482] 48	376 [3325] 42	519 [4589] 28	57
	15 [4]	87 [772] 75	184 [1631] 72	281 [2490] 67	378 [3349] 61	524 [4638] 46	76
	19 [5]	83 [736] 94	181 [1605] 91	280 [2474] 86	378 [3343] 79	525 [4646] 64	95
	27 [7]	73 [643] 133	172 [1522] 130	271 [2400] 124	371 [3279] 117	519 [4597] 101	133
	34 [9]	60 [528] 171	159 [1411] 168	259 [2295] 163	359 [3178] 154	509 [4503] 137	171
	45 [12]	36 [322] 228	137 [1210] 226	237 [2098] 220	337 [2985] 210	488 [4317] 192	228
	57 [15]	9 [80] 285	110 [973] 283	211 [1865] 277	312 [2758] 267		285
Max. Max. Inter. Cont.							
Rotor Width		Overall Efficiency - 70 - 100% <input type="checkbox"/> 40 - 69% <input type="checkbox"/> 0 - 39% <input type="checkbox"/>					
39.4 [1.552] mm [in]		Theoretical Torque - Nm [lb-in]					
		110 [971]	219 [1941]	329 [2912]	439 [3882]	603 [5338]	
		Displacement tested at 54°C [129°F] with an oil viscosity of 46cSt [213 SUS]					

		Pressure - bar [psi]				Max. Cont. Max. Inter.	
230		35 [500]	69 [1000]	104 [1500]	121 [1750]	138 [2000]	166 [2400]
231 cm ³ [14.1 in ³] / rev		Torque - Nm [lb-in], Speed rpm				Intermittent Ratings - 10% of Operation	
Flow - lpm [gpm]	2 [0.5]	98 [864] 7	190 [1678] 4	282 [2493] 1			9
	4 [1]	102 [905] 15	201 [1779] 13	300 [2652] 9	349 [3089] 7	398 [3526] 4	17
	8 [2]	106 [934] 32	212 [1875] 29	318 [2816] 25	371 [3286] 23	425 [3757] 20	33
	11 [3]	104 [925] 48	215 [1900] 46	325 [2876] 42	380 [3363] 39	435 [3851] 36	50
	15 [4]	101 [895] 65	214 [1890] 63	326 [2885] 58	382 [3382] 56	438 [3880] 52	66
	19 [5]	96 [853] 82	210 [1860] 79	324 [2866] 75	381 [3369] 72	438 [3872] 69	83
	27 [7]	84 [743] 115	199 [1761] 112	314 [2780] 108	372 [3289] 105	429 [3798] 101	115
	34 [9]	69 [607] 148	184 [1631] 146	300 [2655] 141	358 [3167] 137	416 [3679] 134	148
	45 [12]	41 [364] 197	157 [1393] 196	274 [2422] 190	332 [2936] 186	390 [3451] 182	197
	57 [15]	9 [76] 247	125 [1111] 245	242 [2145] 240	301 [2662] 236	359 [3180] 231	247
76 [20]		62 [551] 328	181 [1600] 322	240 [2124] 317		329	
Max. Max. Inter. Cont.							
Rotor Width		Overall Efficiency - 70 - 100% <input type="checkbox"/> 40 - 69% <input type="checkbox"/> 0 - 39% <input type="checkbox"/>					
45.5 [1.791] mm [in]		Theoretical Torque - Nm [lb-in]					
		127 [1121]	253 [2242]	380 [3363]	443 [3924]	507 [4484]	608 [5381]
		Displacement tested at 54°C [129°F] with an oil viscosity of 46cSt [213 SUS]					

► Performance data is typical. Performance of production units varies slightly from one motor to another. Operating at maximum continuous pressure and maximum continuous flow simultaneously is not recommended. For additional information on product testing please refer to page 6.

DISPLACEMENT PERFORMANCE

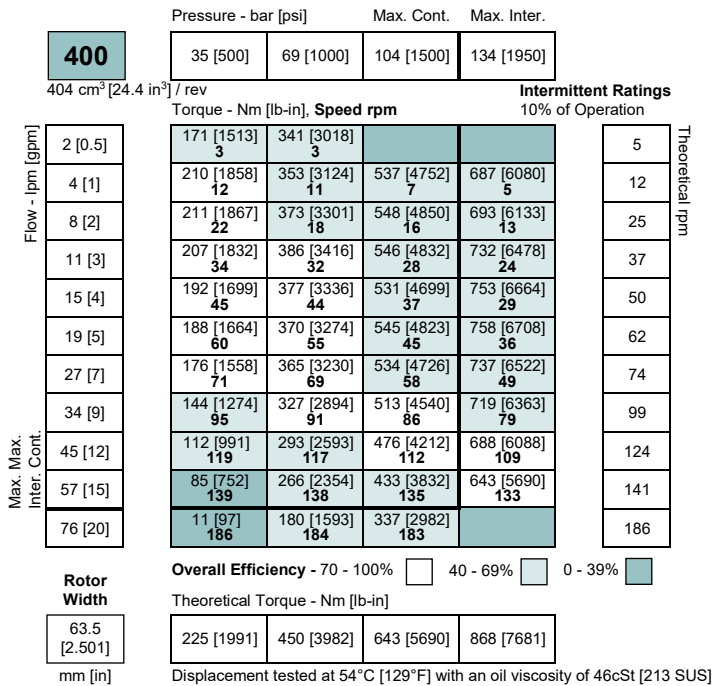
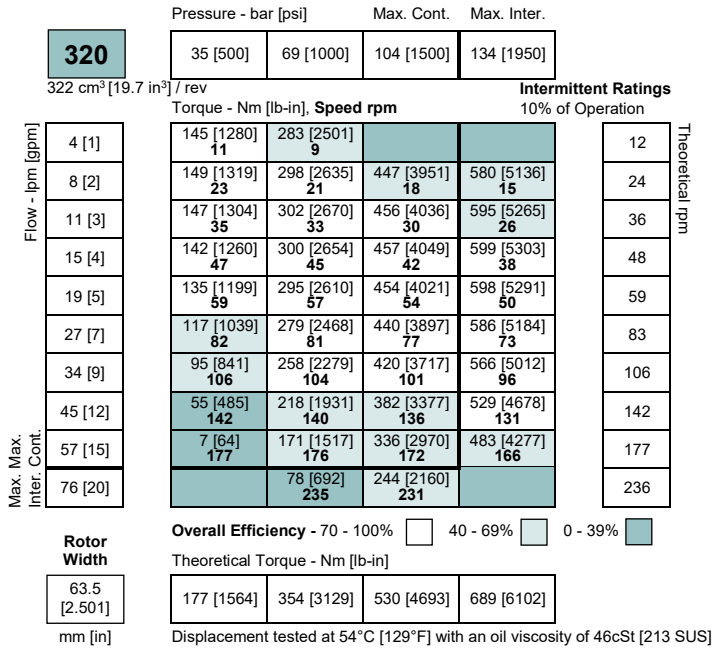

► Performance data is typical. Performance of production units varies slightly from one motor to another. Operating at maximum continuous pressure and maximum continuous flow simultaneously is not recommended. For additional information on product testing please refer to page 6.

HOUSINGS

► Dimensions shown are without paint. Paint thickness can be up to 0.13 [.005].

2-HOLE, SAE A MOUNT, ALIGNED END PORTS

A06 3/4-16 UNF **A0B** G 3/8

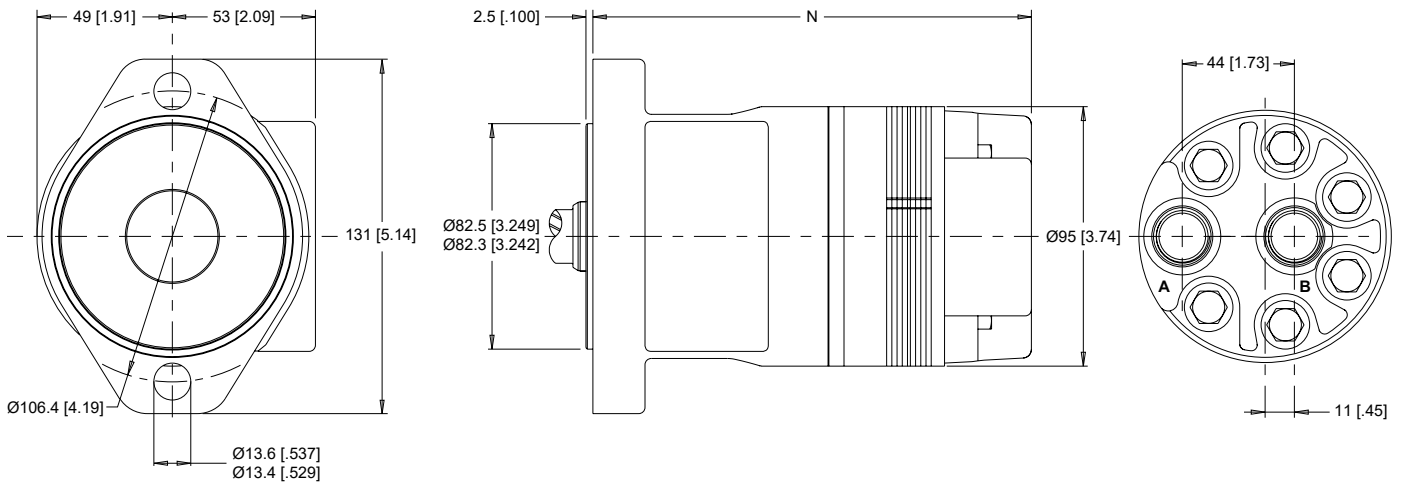

2-HOLE, SAE A MOUNT, ALIGNED PORTS

A10 1/2-14 NPT **A11** 7/8-14 UNF **A18** G 1/2 **A68** G 1/2 (TP)

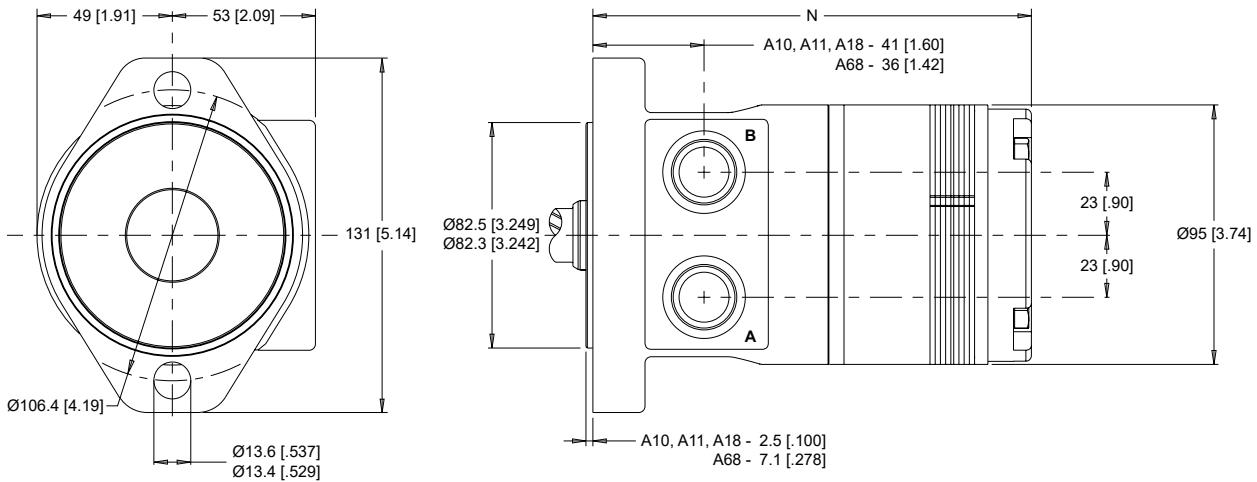

4-HOLE, SQUARE MOUNT, ALIGNED END PORTS

F26 3/4-16 UNF **G2B** G 3/8

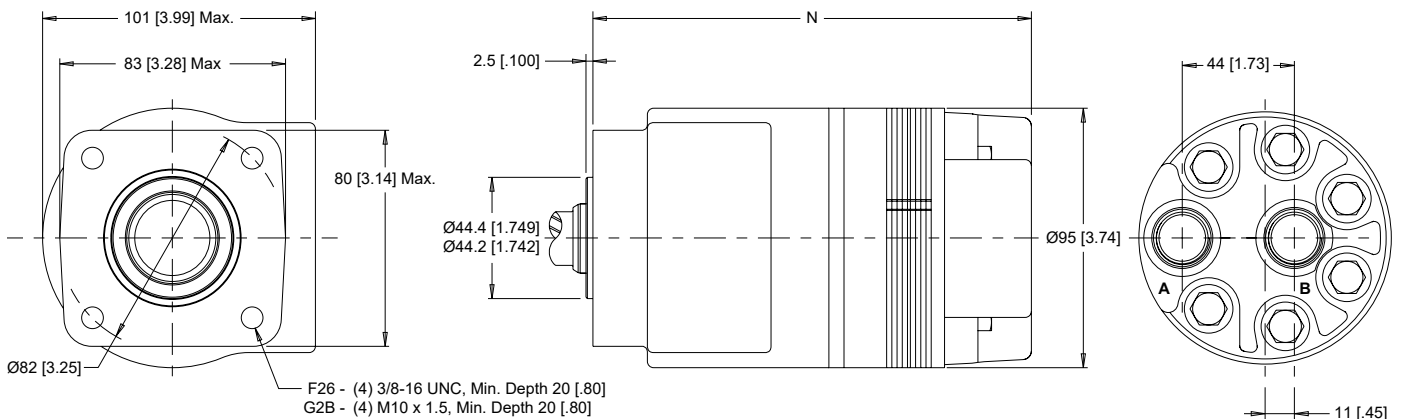

► Dimension N is charted on page 25.

► (TP) - Taller Pilot Height. Refer to detailed drawing for dimensional differences.

WG(275/276 Series)

Light Duty Hydraulic Motor

HOUSINGS

► Dimensions shown are without paint. Paint thickness can be up to 0.13 [.005].

4-HOLE, SQUARE MOUNT, ALIGNED PORTS

F30 1/2-14 NPT **F31** 7/8-14 UNF **F38** G 1/2

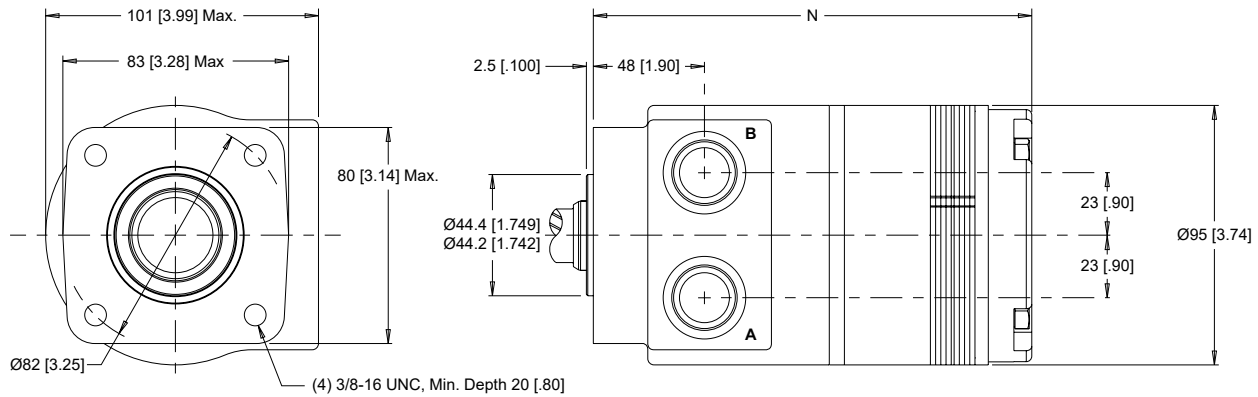

4-HOLE, WHEEL MOUNT, ALIGNED END PORTS

W26 3/4-16 UNF **W2B** G 3/8

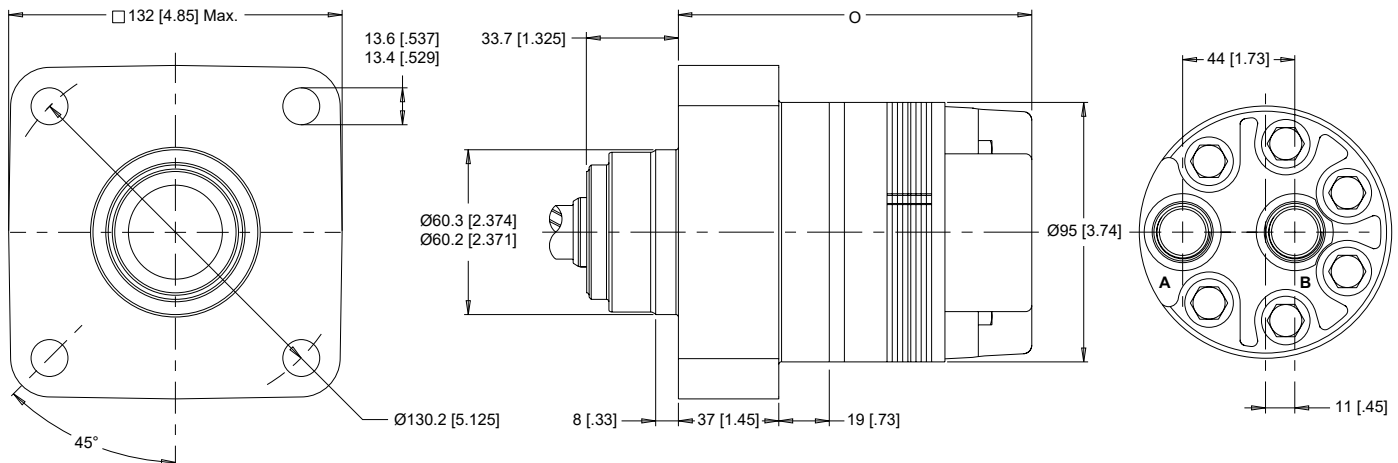

4-HOLE, WHEEL MOUNT, ALIGNED PORTS

W30 1/2-14 NPT **W31** 7/8-14 UNF **W38** G 1/2

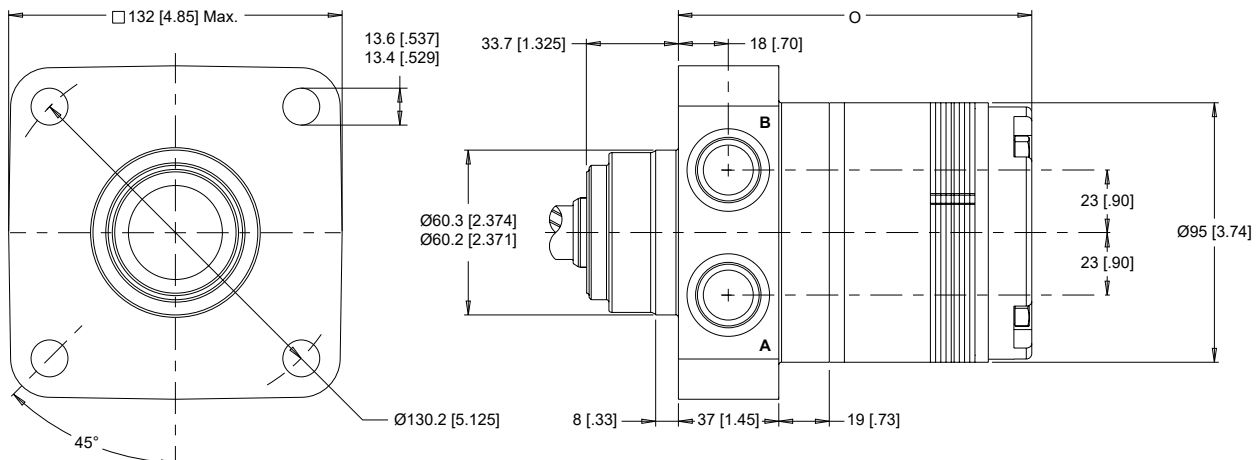

► Dimensions N & O are charted on page 25.

TECHNICAL INFORMATION

ALLOWABLE SHAFT LOAD / BEARING CURVE

The bearing curve represents allowable bearing loads based on ISO 281 bearing capacity for an L_{10} life of 2,000 hours at 100 rpm. Radial loads for speeds other than 100 rpm may be calculated using the multiplication factor table on page 8.

SAE A & SQUARE MOUNTS

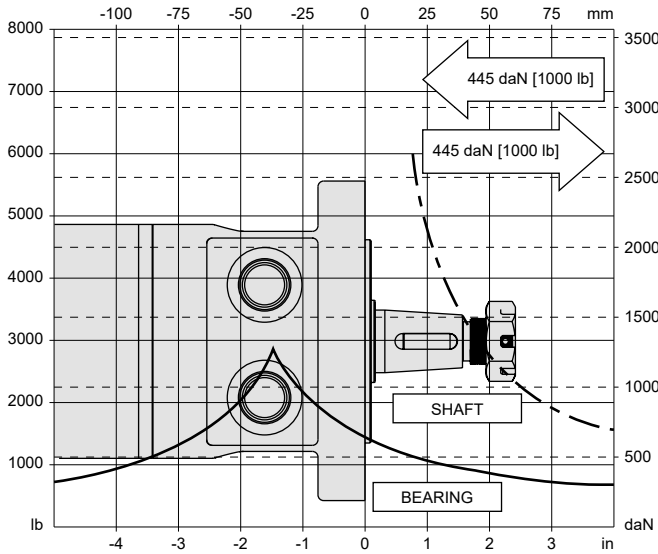

LENGTH & WEIGHT CHART

Dimension N is the overall motor length from the rear of the motor to the mounting flange surface and is referenced on detailed housing drawings listed on pages 23-24.

N	Side Ports	End Ports	Weight
#	mm [in]	mm [in]	kg [lb]
040	137 [5.39]	156 [6.16]	7.3 [15.9]
045	138 [5.43]	157 [6.19]	7.3 [16.0]
060	141 [5.55]	160 [6.31]	7.4 [16.3]
070	143 [5.63]	162 [6.38]	7.5 [16.4]
090	147 [5.79]	166 [6.52]	7.6 [16.8]
100	149 [5.87]	168 [6.62]	7.7 [17.0]
130	155 [6.10]	174 [6.84]	8.0 [17.5]
160	161 [6.34]	180 [7.09]	8.2 [18.0]
200	169 [6.65]	188 [7.39]	8.5 [18.7]
230	175 [6.89]	194 [7.63]	8.7 [19.2]
320	193 [7.60]	212 [8.34]	9.5 [20.8]
400	193 [7.60]	212 [8.34]	9.5 [20.8]

► If figuring dimension N and using an A68 housing, subtract 4.5 [1.78] from the dimension.

Dimension O is the overall motor length from the rear of the motor to the mounting flange surface and is referenced on detailed housing drawings listed on page 24.

O	Side Ports	End Ports	Weight
#	mm [in]	mm [in]	kg [lb]
040	106 [4.17]	125 [4.93]	7.6 [16.7]
045	106 [4.17]	125 [4.95]	7.6 [16.8]
060	110 [4.33]	129 [5.07]	7.7 [17.0]
070	112 [4.41]	131 [5.15]	7.8 [17.2]
090	115 [4.53]	134 [5.29]	8.0 [17.5]
100	118 [4.65]	137 [5.39]	8.0 [17.7]
130	123 [4.84]	142 [5.61]	8.3 [18.2]
160	130 [5.12]	149 [5.86]	8.5 [18.8]
200	137 [5.39]	156 [6.16]	8.9 [19.5]
230	144 [5.67]	163 [6.40]	9.1 [20.0]
320	162 [6.38]	181 [7.11]	9.8 [21.6]
400	162 [6.38]	181 [7.11]	9.8 [21.6]

WHEEL MOUNTS

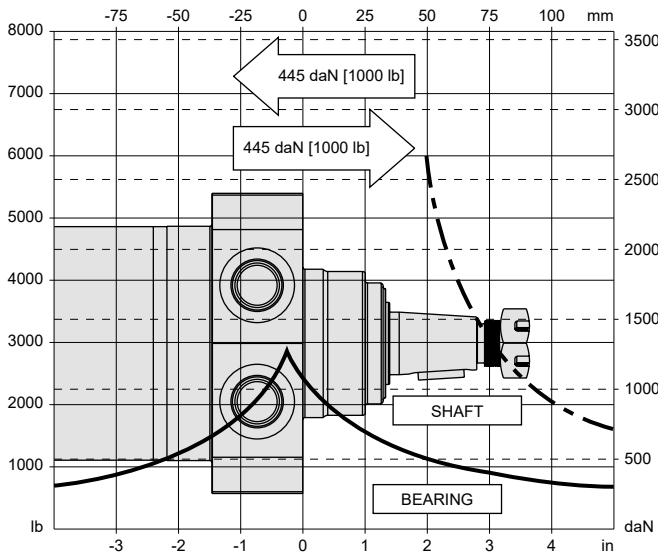

► The overall motor weights listed in both charts above are referencing the end ported options, which are the heavier of the two. 275 & 276 series motor weights can vary $\pm .5$ kg [1 lb] depending on model configurations such as housing, shaft, endcover, options etc.

SHAFTS

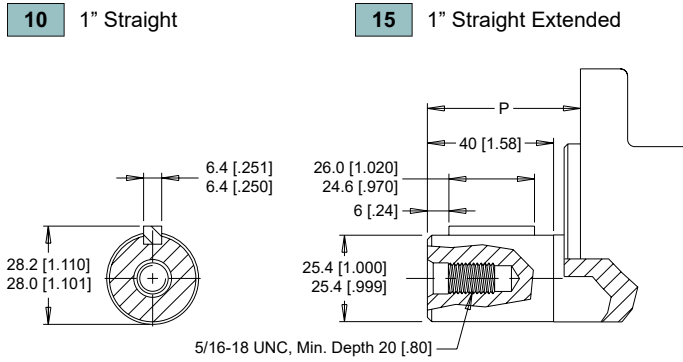

Max. Torque: 655 Nm [5800 lb-in]

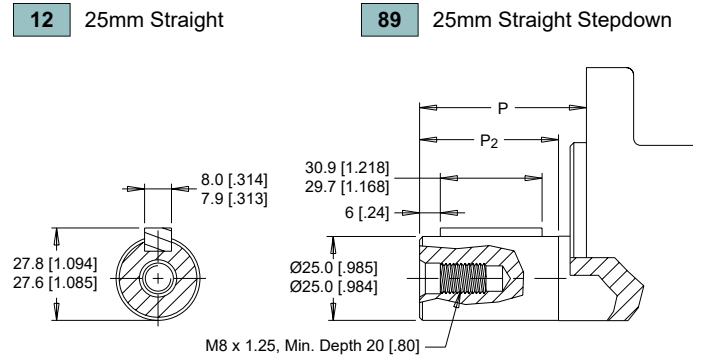

Max. Torque: 678 Nm [6000 lb-in]

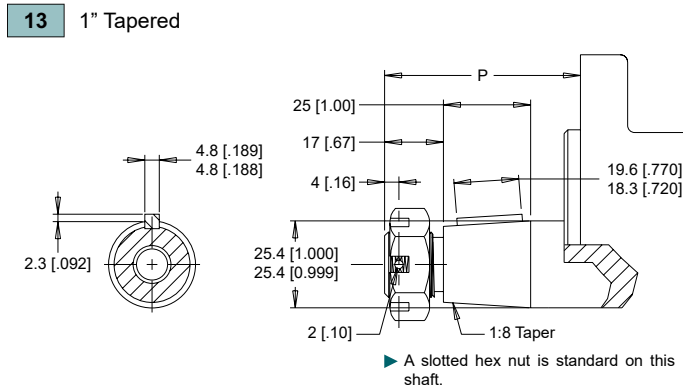

Max. Torque: 655 Nm [5800 lb-in]

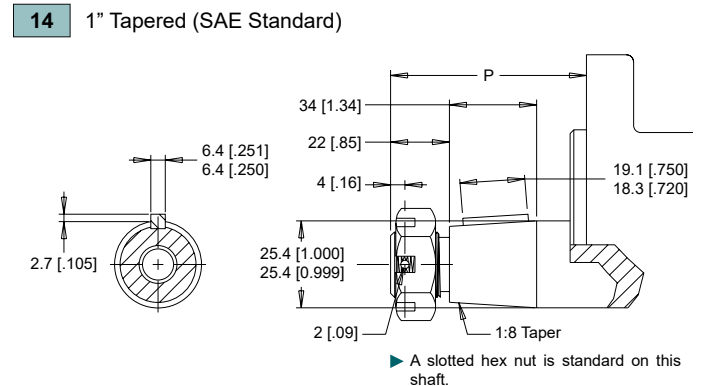

Max. Torque: 655 Nm [5800 lb-in]

MOUNTING / SHAFT LENGTH CHART

Dimension P is the overall distance from the motor mounting surface to the end of the shaft.

Additional shaft length information, if necessary, is noted as P₂ and does not increase or decrease the listed P dimensions in this chart. The overall shaft lengths are already factored into the overall distance from the mounting surface to the end of the shaft.

P #	Square & A Mounts	Wheel Mounts	P ₂ mm [in]
	mm [in]	mm [in]	
10	45 [1.77]	76 [2.99]	N/A
12	49 [1.94]	80 [3.16]	43 [1.70]
13	56 [2.21]	87 [3.43]	N/A
14	61 [2.41]	92 [3.63]	N/A
15	64 [2.50]	95 [3.77]	N/A
89	51 [2.00]	82 [3.22]	45 [1.78]

▶ Add 4.5 [1.78] to shaft dimension P when a A68 housing is used.

ORDERING INFORMATION

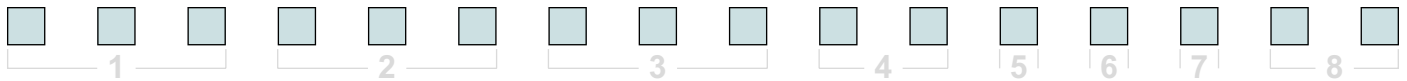

1. CHOOSE SERIES DESIGNATION

275 Reverse Rotation	276 Standard Rotation
-----------------------------	------------------------------

► The 275 & 276 series are bi-directional. For applications requiring the motor to rotate in only one direction, shaft seal life may be prolonged by pressurizing the A port of the motor.

2. SELECT A DISPLACEMENT OPTION

040 41 cm ³ /rev [2.5 in ³ /rev]	130 129 cm ³ /rev [7.9 in ³ /rev]
045 44 cm ³ /rev [2.7 in ³ /rev]	160 161 cm ³ /rev [9.8 in ³ /rev]
060 60 cm ³ /rev [3.6 in ³ /rev]	200 200 cm ³ /rev [12.2 in ³ /rev]
070 70 cm ³ /rev [4.3 in ³ /rev]	230 231 cm ³ /rev [14.1 in ³ /rev]
090 88 cm ³ /rev [5.4 in ³ /rev]	320 322 cm ³ /rev [19.7 in ³ /rev]
100 100 cm ³ /rev [6.1 in ³ /rev]	400 404 cm ³ /rev [24.4 in ³ /rev]

3. SELECT A MOUNT & PORT OPTION

A06 2-Hole, SAE A Mount, Aligned End Ports, 3/4-16 UNF
A10 2-Hole, SAE A Mount, Aligned Ports, 1/2-14 NPT
A11 2-Hole, SAE A Mount, Aligned Ports, 7/8-14 UNF
A18 2-Hole, SAE A Mount, Aligned Ports, G 1/2
A68 2-Hole, SAE A Mount, Aligned Ports, G 1/2 (TP)
F26 4-Hole, Square Mount, Aligned End Ports, 3/4-16 UNF
F30 4-Hole, Square Mount, Aligned Ports, 1/2-14 NPT
F31 4-Hole, Square Mount, Aligned Ports, 7/8-14 UNF
F38 4-Hole, Square Mount, Aligned Ports, G 1/2

► (TP) - Tall pilot. The speed sensor option is not available on tall pilot or wheel mount housings.

3. SELECT A MOUNT & PORT OPTION

W26 4-Hole, Wheel Mount, Aligned End Ports, 3/4-16 UNF
W30 4-Hole, Wheel Mount, Aligned Ports, 1/2-14 NPT
W31 4-Hole, Wheel Mount, Aligned Ports, 7/8-14 UNF
W38 4-Hole, Wheel Mount, Aligned Ports, G 1/2

4. SELECT A SHAFT OPTION

10 1" Straight	14 1" Tapered (SAE Standard)
12 25mm Straight	15 1" Straight Extended
13 1" Tapered	89 25mm Straight Stepdown

► The 15 extended shaft is designed for use with one of the speed sensor options listed in STEP 7.

5. SELECT A PAINT OPTION

A Black
B Black, Unpainted Mounting Surface

6. SELECT A VALVE CAVITY / CARTRIDGE OPTION

A None

7. SELECT AN ADD-ON OPTION

A Standard
B Lock Nut
C Solid Hex Nut
W Speed Sensor, Dual, 4-Pin Male Weatherpack Connector
X Speed Sensor, Dual, 4-Pin M12 Male Connector
Y Speed Sensor, Single, 3-Pin Male Weatherpack Connector
Z Speed Sensor, Single, 4-Pin M12 Male Connector

8. SELECT A MISCELLANEOUS OPTION

AA None
AC Freeturning Rotor

WG(277/278 Series)
Light Duty Hydraulic Motor

HOUSINGS

► Dimensions shown are without paint. Paint thickness can be up to 0.13 [.005].

2-HOLE, SAE A MOUNT, ALIGNED END PORTS

A10 1/2-14 NPT **A11** 7/8-14 UNF

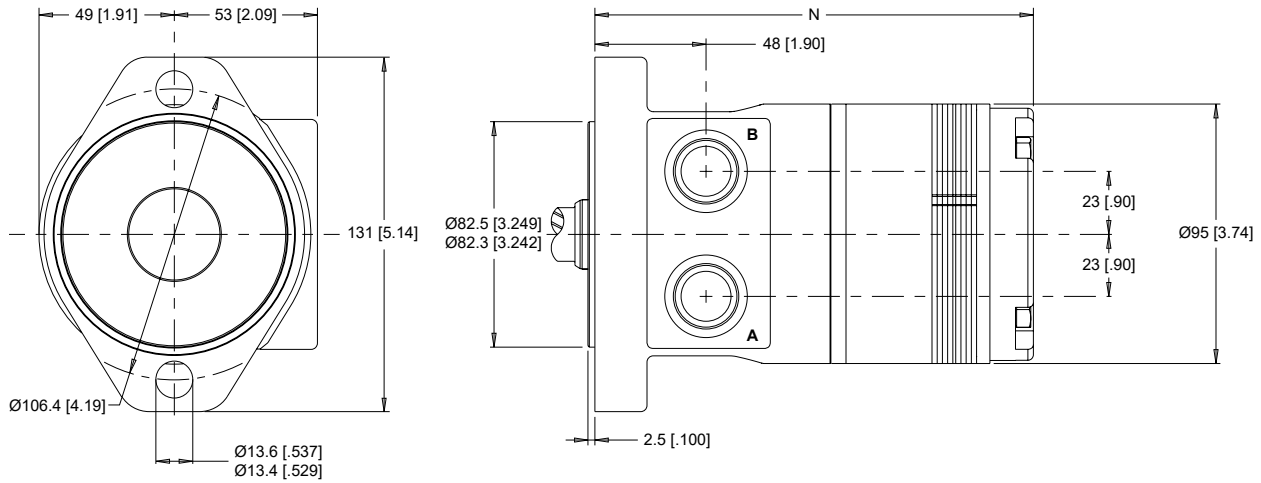

2-HOLE, SAE A MOUNT, ALIGNED MANIFOLD PORTS

A17 1/2" Drilled

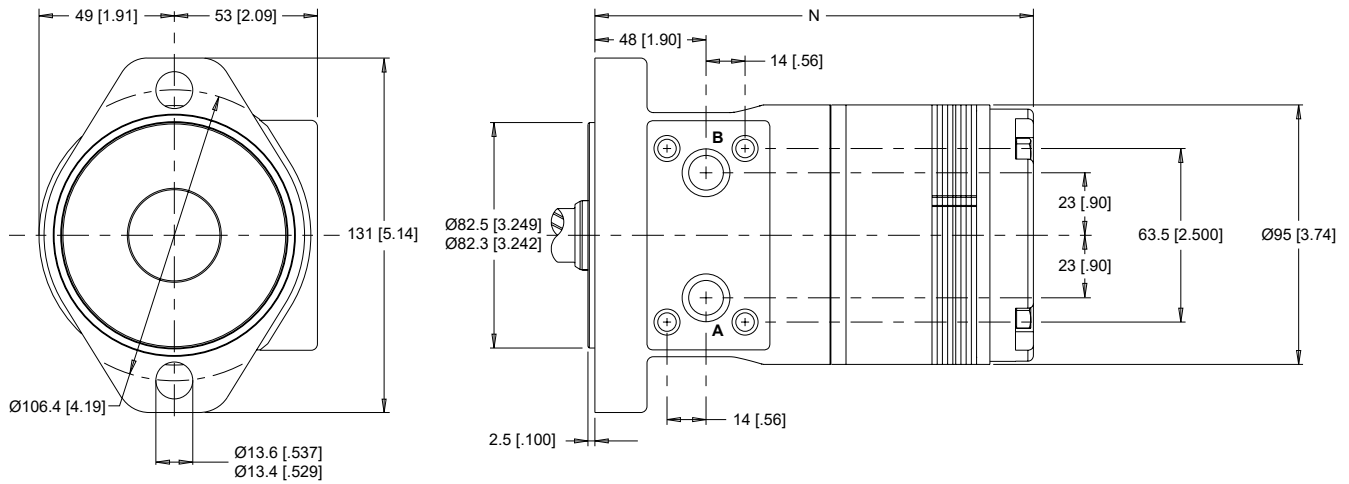

► Dimension N and allowable sideload information is found on page 30.

HOUSINGS

► Dimensions shown are without paint. Paint thickness can be up to 0.13 [.005].

4-HOLE, SQUARE MOUNT, ALIGNED PORTS

F30 1/2-14 NPT **F31** 7/8-14 UNF

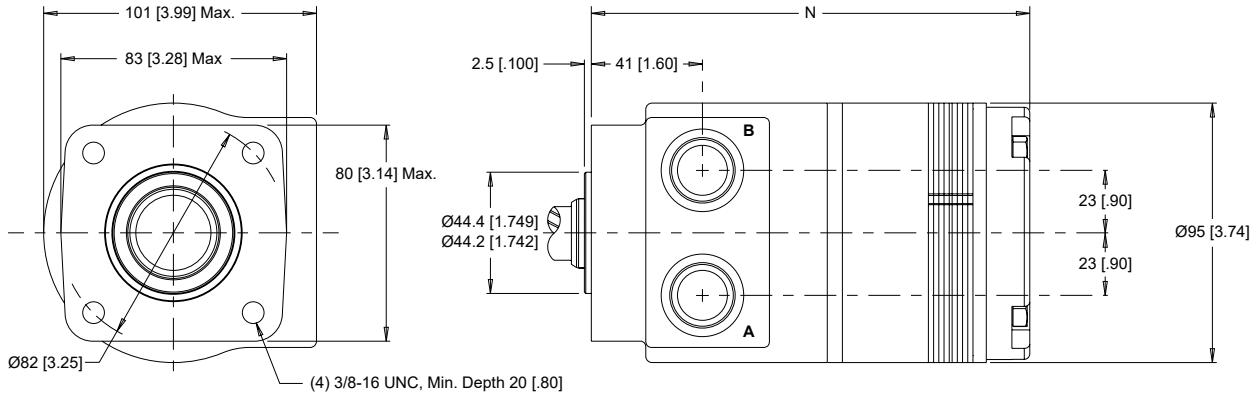

4-HOLE, WHEEL MOUNT, ALIGNED PORTS

W30 1/2-14 NPT

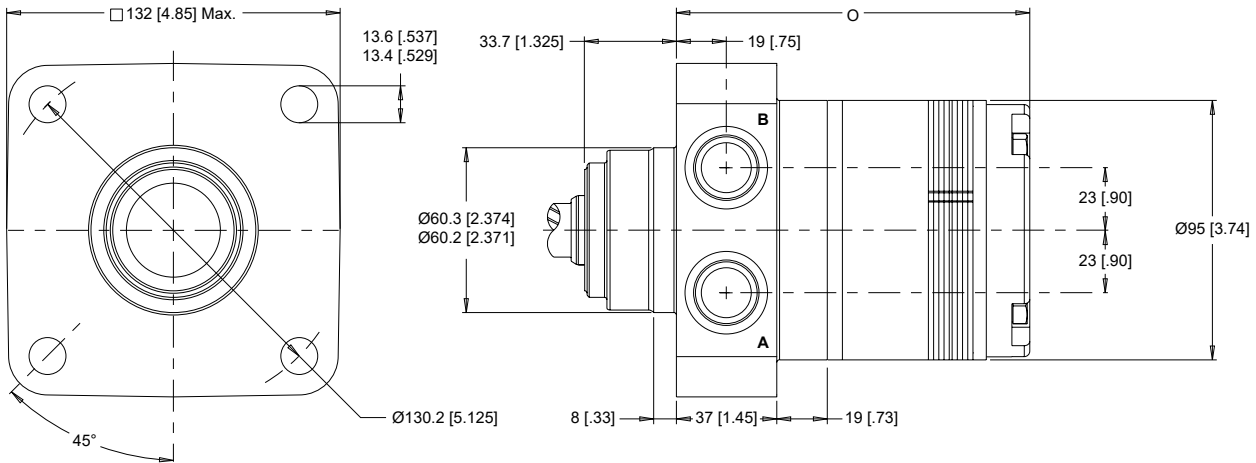

► Dimensions N & O and allowable side load information is found on page 30.

TECHNICAL INFORMATION

ALLOWABLE SHAFT LOAD / BEARING CURVE

The bearing curve represents allowable bearing loads based on ISO 281 bearing capacity for an L_{10} life of 2,000 hours at 100 rpm. Radial loads for speeds other than 100 rpm may be calculated using the multiplication factor table on page 7.

SAE A & SQUARE MOUNTS

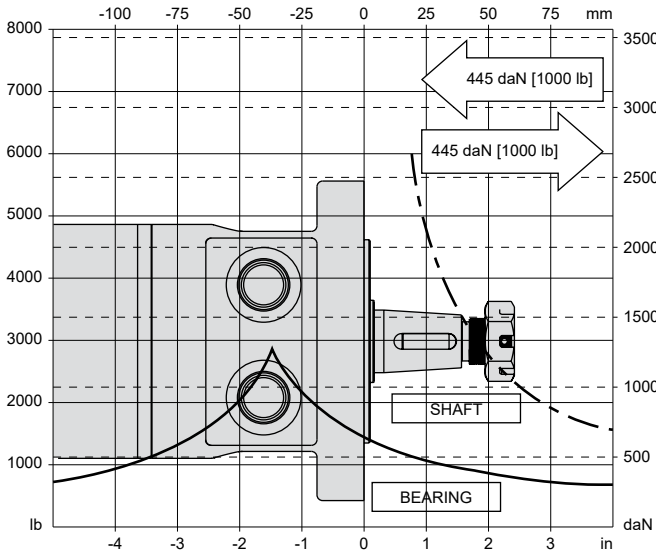

LENGTH & WEIGHT CHART

Dimension N is the overall motor length from the rear of the motor to the mounting flange surface and is referenced on detailed housing drawings listed on pages 28-29.

N	Side Ports	End Ports	Weight
#	mm [in]	mm [in]	kg [lb]
040	137 [5.39]	156 [6.16]	7.3 [15.9]
045	138 [5.43]	157 [6.19]	7.3 [16.0]
060	141 [5.55]	160 [6.31]	7.4 [16.3]
070	143 [5.63]	162 [6.38]	7.5 [16.4]
090	147 [5.79]	166 [6.52]	7.6 [16.8]
100	149 [5.87]	168 [6.62]	7.7 [17.0]
130	155 [6.10]	174 [6.84]	8.0 [17.5]
160	161 [6.34]	180 [7.09]	8.2 [18.0]
200	169 [6.65]	188 [7.39]	8.5 [18.7]
230	175 [6.89]	194 [7.63]	8.7 [19.2]
320	193 [7.60]	212 [8.34]	9.5 [20.8]
400	193 [7.60]	212 [8.34]	9.5 [20.8]

► If figuring dimension N and using an A68 housing, subtract 4.5 [1.78] from the dimension.

Dimension O is the overall motor length from the rear of the motor to the mounting flange surface and is referenced on detailed housing drawings listed on page 29.

O	Side Ports	End Ports	Weight
#	mm [in]	mm [in]	kg [lb]
040	106 [4.17]	125 [4.93]	7.6 [16.7]
045	106 [4.17]	125 [4.95]	7.6 [16.8]
060	110 [4.33]	129 [5.07]	7.7 [17.0]
070	112 [4.41]	131 [5.15]	7.8 [17.2]
090	115 [4.53]	134 [5.29]	8.0 [17.5]
100	118 [4.65]	137 [5.39]	8.0 [17.7]
130	123 [4.84]	142 [5.61]	8.3 [18.2]
160	130 [5.12]	149 [5.86]	8.5 [18.8]
200	137 [5.39]	156 [6.16]	8.9 [19.5]
230	144 [5.67]	163 [6.40]	9.1 [20.0]
320	162 [6.38]	181 [7.11]	9.8 [21.6]
400	162 [6.38]	181 [7.11]	9.8 [21.6]

► The overall motor weights listed in both charts above are referencing the end ported options, which are the heavier of the two. 275 & 276 series motor weights can vary $\pm .5$ kg [1 lb] depending on model configurations such as housing, shaft, endcover, options etc.

WHEEL MOUNTS

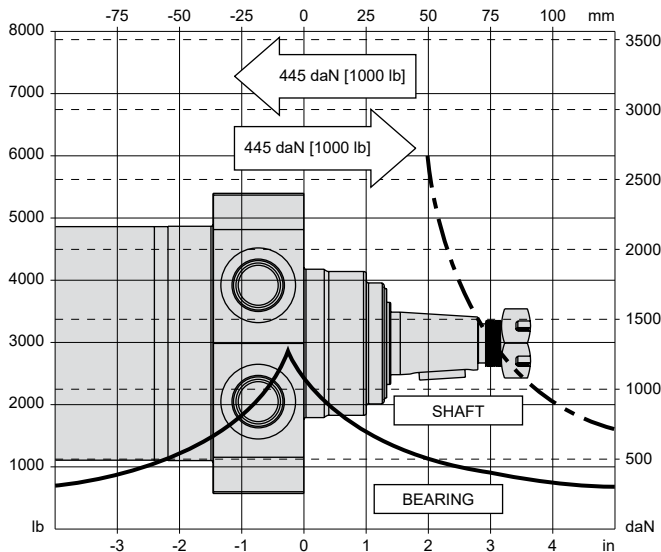

SHAFTS

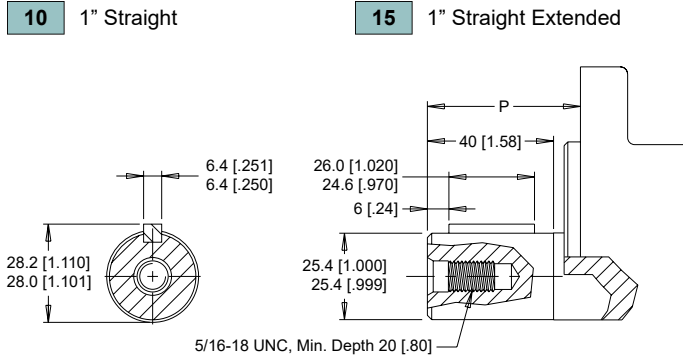

Max. Torque: 655 Nm [5800 lb-in]

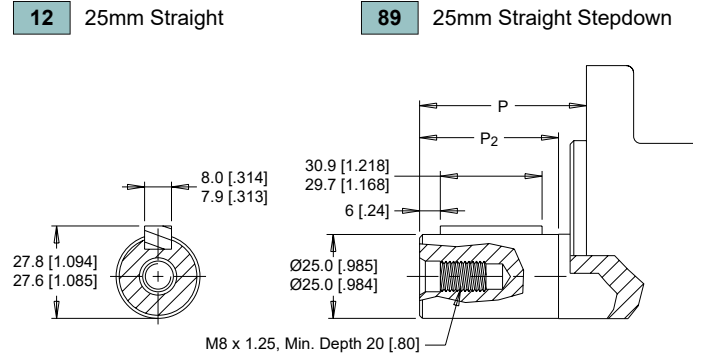
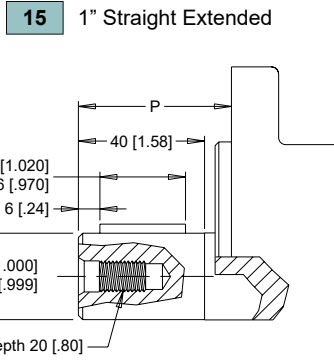

Max. Torque: 678 Nm [6000 lb-in]

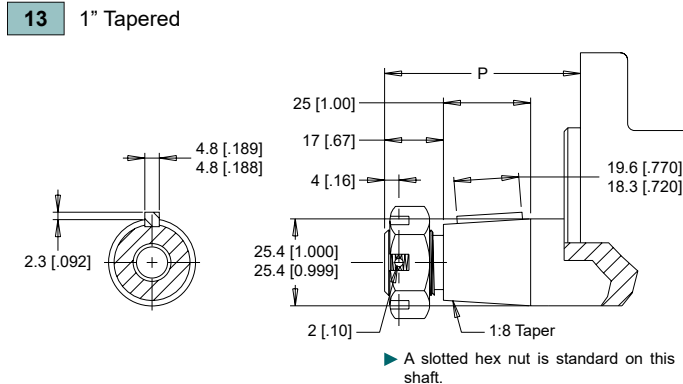
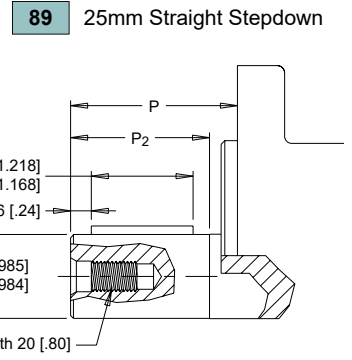

Max. Torque: 655 Nm [5800 lb-in]

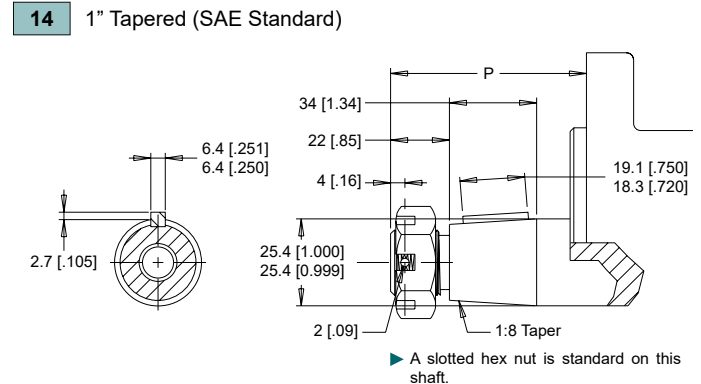

Max. Torque: 655 Nm [5800 lb-in]

MOUNTING / SHAFT LENGTH CHART

Dimension P is the overall distance from the motor mounting surface to the end of the shaft.

Additional shaft length information, if necessary, is noted as P₂ and does not increase or decrease the listed P dimensions in this chart. The overall shaft lengths are already factored into the overall distance from the mounting surface to the end of the shaft.

P	Square & A Mounts	Wheel Mounts	P ₂
#	mm [in]	mm [in]	mm [in]
10	45 [1.77]	76 [2.99]	N/A
12	49 [1.94]	80 [3.16]	43 [1.70]
13	56 [2.21]	87 [3.43]	N/A
14	61 [2.41]	92 [3.63]	N/A
15	64 [2.50]	95 [3.77]	N/A
89	51 [2.00]	82 [3.22]	45 [1.78]

ORDERING INFORMATION

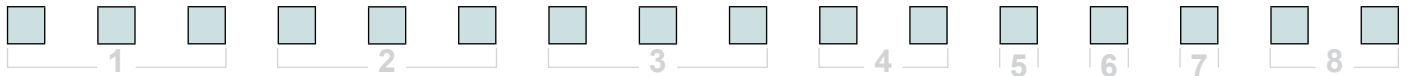

1. CHOOSE SERIES DESIGNATION

<p>277 Reverse Rotation</p>	<p>278 Standard Rotation</p>
------------------------------------	-------------------------------------

► The 277 & 278 series are bi-directional. For applications requiring the motor to rotate in only one direction, shaft seal life may be prolonged by pressurizing the A port of the motor.

2. SELECT A DISPLACEMENT OPTION

040	41 cm ³ /rev [2.5 in ³ /rev]	130	129 cm ³ /rev [7.9 in ³ /rev]
045	44 cm ³ /rev [2.7 in ³ /rev]	160	161 cm ³ /rev [9.8 in ³ /rev]
060	60 cm ³ /rev [3.6 in ³ /rev]	200	200 cm ³ /rev [12.2 in ³ /rev]
070	70 cm ³ /rev [4.3 in ³ /rev]	230	231 cm ³ /rev [14.1 in ³ /rev]
090	88 cm ³ /rev [5.4 in ³ /rev]	320	322 cm ³ /rev [19.7 in ³ /rev]
100	100 cm ³ /rev [6.1 in ³ /rev]	400	404 cm ³ /rev [24.4 in ³ /rev]

3. SELECT A MOUNT & PORT OPTION

A10	2-Hole, SAE A Mount, Aligned Ports, 1/2-14 NPT
A11	2-Hole, SAE A Mount, Aligned Ports, 7/8-14 UNF
A17	2-Hole, SAE A Mount, Aligned Manifold Ports, 1/2" Drilled
F30	4-Hole, Square Mount, Aligned Ports, 1/2-14 NPT
F31	4-Hole, Square Mount, Aligned Ports, 7/8-14 UNF
W31	4-Hole, Wheel Mount, Aligned Ports, 7/8-14 UNF

► The speed sensor option is not available on wheel mount housings.

4. SELECT A SHAFT OPTION

10	1" Straight	14	1" Tapered (SAE Standard)
12	25mm Straight	15	1" Straight Extended
13	1" Tapered	89	25mm Straight Stepdown

► The 15 extended shaft is designed for use with one of the speed sensor options listed in STEP 7.

5. SELECT A PAINT OPTION

A	Black
B	Black, Unpainted Mounting Surface

6. SELECT A VALVE CAVITY / CARTRIDGE OPTION

A	None
----------	------

7. SELECT AN ADD-ON OPTION

A	Standard
B	Lock Nut
C	Solid Hex Nut
W	Speed Sensor, Dual, 4-Pin Male Weatherpack Connector
X	Speed Sensor, Dual, 4-Pin M12 Male Connector
Y	Speed Sensor, Single, 3-Pin Male Weatherpack Connector
Z	Speed Sensor, Single, 4-Pin M12 Male Connector

8. SELECT A MISCELLANEOUS OPTION

AA	None
AC	Freeturning Rotor

HOUSINGS

► Dimensions shown are without paint. Paint thickness can be up to 0.13 [.005].

2-HOLE, SAE A MOUNT, OFFSET MANIFOLD PORTS

A63 G 1/2

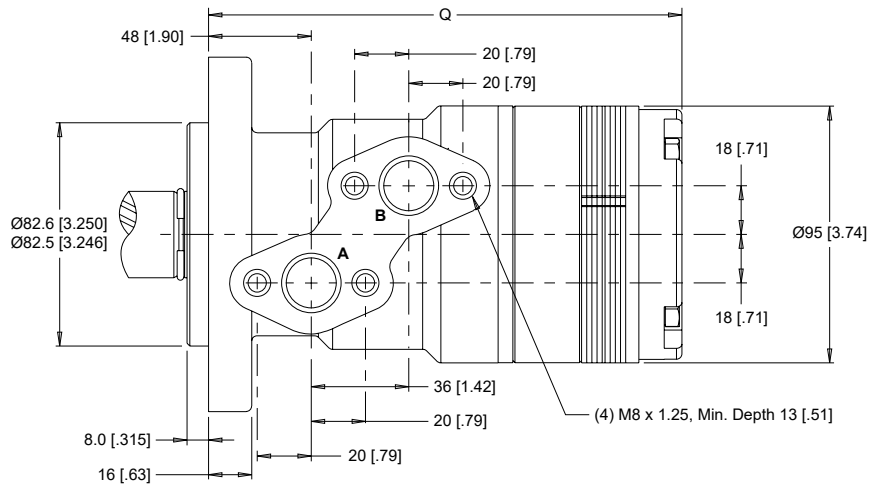
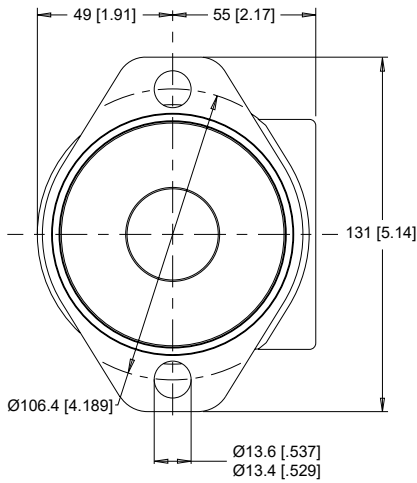

4-HOLE, MAGNETO MOUNT, OFFSET MANIFOLD PORTS

AC3 G 1/2

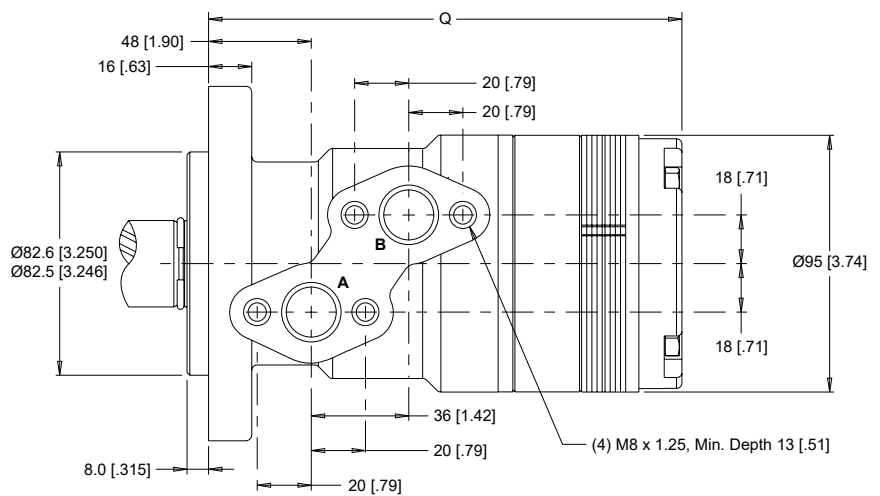
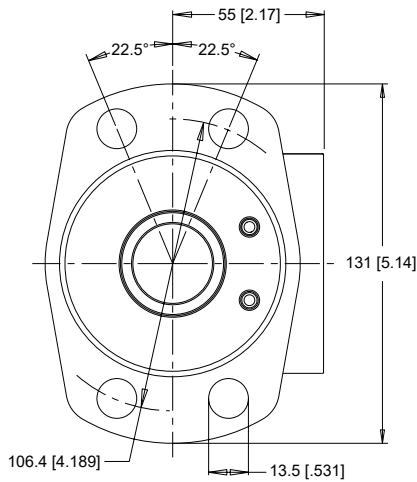

4-HOLE, SAE A MOUNT, OFFSET MANIFOLD PORTS

AG3 G 1/2

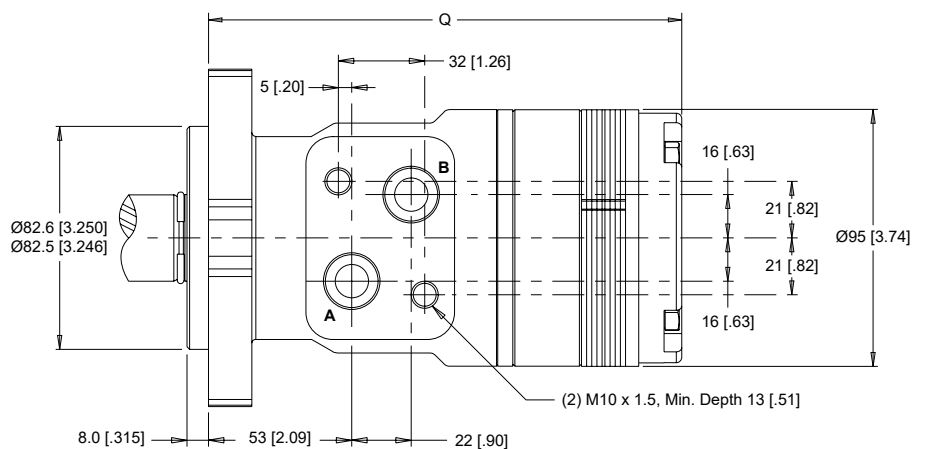
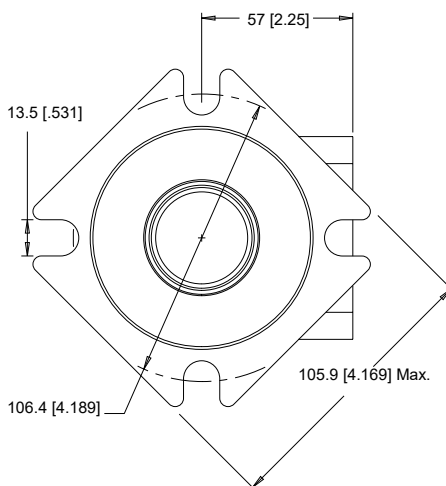

► Dimension Q is found on page 35.

WG (280/281 Series)

Light Duty Hydraulic Motor

HOUSINGS

► Dimensions shown are without paint. Paint thickness can be up to 0.13 [.005].

2-HOLE, SAE A MOUNT, ALIGNED PORTS

A68 G 1/2

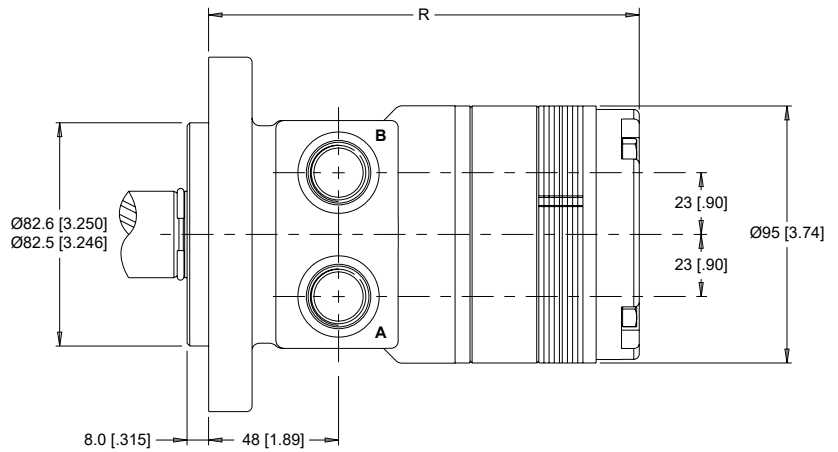
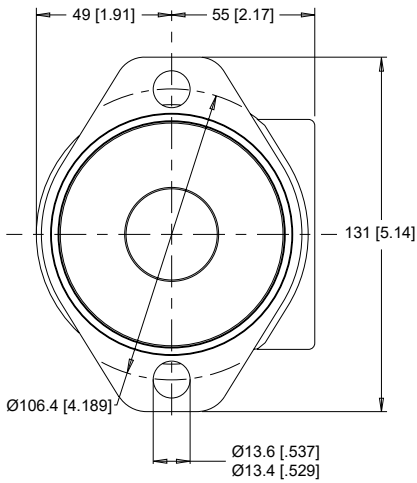

4-HOLE, MAGNETO MOUNT, ALIGNED PORTS

AC8 G 1/2

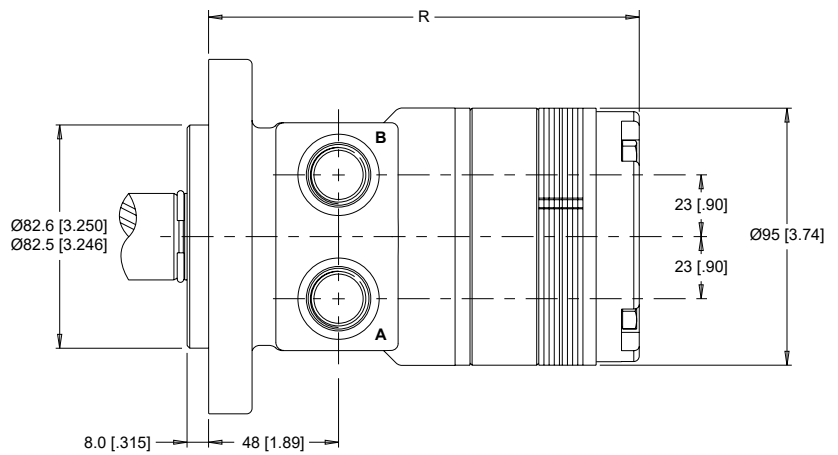
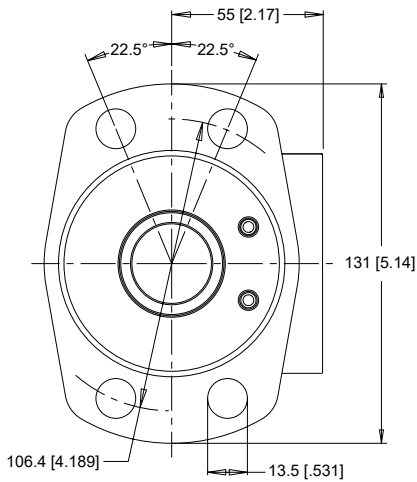

► Dimension R is found on page 35.

SHAFTS

21 32mm Straight

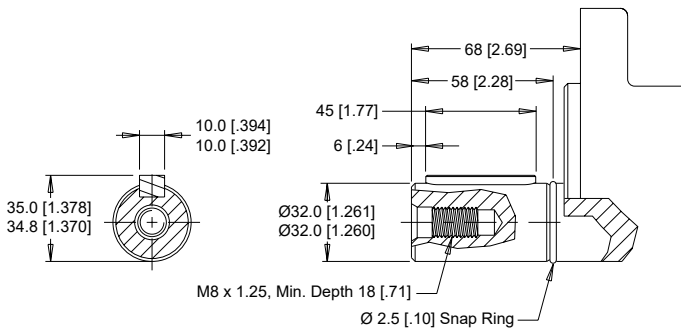

Max. Torque: 882 Nm [7804 lb-in]

TECHNICAL INFORMATION

ALLOWABLE SHAFT LOAD / BEARING CURVE

The bearing curve represents allowable bearing loads based on ISO 281 bearing capacity for an L_{10} life of 2,000 hours at 100 rpm. Radial loads for speeds other than 100 rpm may be calculated using the multiplication factor table on page 7.

ALL 280 & 281 SERIES MOUNTS

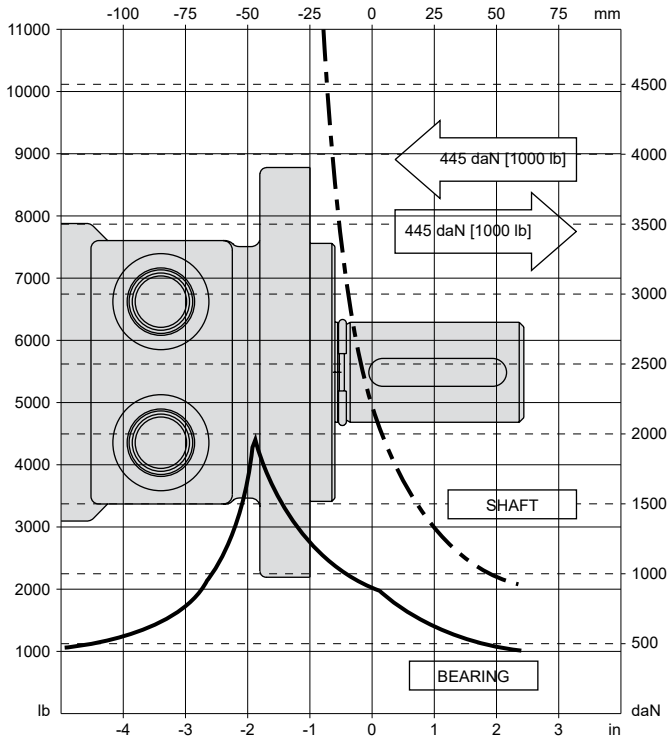

LENGTH & WEIGHT CHART

Dimension Q is the overall motor length from the rear of the motor to the mounting flange surface and is referenced on detailed housing drawings listed on page 33.

Q	Length	A63 & AC3 Weight	AG3 Weight
#	mm [in]	kg [lb]	kg [lb]
040	157 [6.18]	6.1 [13.4]	6.4 [14.1]
045	158 [6.22]	6.2 [13.6]	6.4 [14.1]
060	161 [6.34]	6.3 [13.9]	6.6 [14.5]
070	163 [6.42]	6.4 [14.1]	6.7 [14.7]
090	166 [6.54]	6.6 [14.5]	6.9 [15.2]
100	169 [6.65]	6.7 [14.7]	7.0 [15.4]
130	175 [6.89]	7.0 [15.4]	7.2 [15.8]
160	181 [7.13]	7.3 [16.1]	7.5 [16.5]
200	189 [7.44]	7.6 [16.7]	7.9 [17.4]
230	195 [7.68]	7.9 [17.4]	8.2 [18.0]
320	213 [8.39]	8.6 [18.9]	9.0 [19.8]
400	213 [8.39]	8.6 [18.9]	9.0 [19.8]

Dimension R is the overall motor length from the rear of the motor to the mounting flange surface and is referenced on detailed housing drawings listed on page 34.

R	Length	Weight
#	mm [in]	kg [lb]
040	141 [5.55]	5.6 [12.3]
045	142 [5.59]	5.6 [12.3]
060	145 [5.71]	5.8 [12.8]
070	147 [5.79]	5.9 [13.0]
090	150 [5.91]	6.1 [13.4]
100	153 [6.02]	6.2 [13.6]
130	159 [6.26]	6.5 [14.3]
160	165 [6.50]	6.8 [15.0]
200	173 [6.81]	7.1 [15.6]
230	179 [7.05]	7.4 [16.3]
320	197 [7.76]	8.2 [18.0]
400	197 [7.76]	8.2 [18.0]

► 280 & 281 series motor weights can vary $\pm .5$ kg [1 lb] depending on model configurations such as housing, shaft, endcover, options etc.

ORDERING INFORMATION



1. CHOOSE SERIES DESIGNATION

- 280** Reverse Rotation
- 281** Standard Rotation

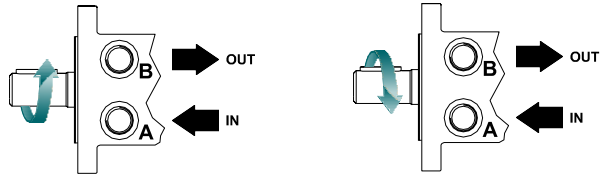

► The 280 & 281 series are bi-directional. For applications requiring the motor to rotate in only one direction, shaft seal life may be prolonged by pressurizing the A port of the motor.

2. SELECT A DISPLACEMENT OPTION

040	41 cm ³ /rev [2.5 in ³ /rev]	130	129 cm ³ /rev [7.9 in ³ /rev]
045	44 cm ³ /rev [2.7 in ³ /rev]	160	161 cm ³ /rev [9.8 in ³ /rev]
060	60 cm ³ /rev [3.6 in ³ /rev]	200	200 cm ³ /rev [12.2 in ³ /rev]
070	70 cm ³ /rev [4.3 in ³ /rev]	230	231 cm ³ /rev [14.1 in ³ /rev]
090	88 cm ³ /rev [5.4 in ³ /rev]	320	322 cm ³ /rev [19.7 in ³ /rev]
100	100 cm ³ /rev [6.1 in ³ /rev]	400	404 cm ³ /rev [24.4 in ³ /rev]

3. SELECT A MOUNT & PORT OPTION

- A63** 2-Hole, SAE A Mount, Offset Manifold Ports, G 1/2
- A68** 2-Hole, SAE A Mount, Aligned Ports, G 1/2
- AC3** 4-Hole, Magneto Mount, Offset Manifold Ports, G 1/2
- AC8** 4-Hole, Magneto Mount, Aligned Ports, G 1/2
- AG3** 4-Hole, SAE A Mount, Offset Manifold Ports, G 1/2

4. SELECT A SHAFT OPTION

- 21** 32mm Straight

5. SELECT A PAINT OPTION

- A** Black
- B** Black, Unpainted Mounting Surface

6. SELECT A VALVE CAVITY / CARTRIDGE OPTION

- A** None

7. SELECT AN ADD-ON OPTION

- A** Standard

8. SELECT A MISCELLANEOUS OPTION

- AA** None
- AC** Freeturning Rotor